

# STEREO PHONO AMPLIFIER C-37



Accuphase Laboratory, Inc.

1

C-37 is the succession model of C-27.

C-37 has been totally changed the amplifier configuration from former model C-27, and it achieved 30% lower noise than C-27.

# Functions

- Phono Cartridge Type Select
  - MC / MM
- Gain Select
  - Low / High(+10dB)
- Subsonic Filter
  - 10Hz, 12dB/oct
- Input Impedance Select
  - MC: 3,10,30,100,300,1k $\Omega$    MM: 1k,47k,100k $\Omega$



C-37 has a lot of functions to bring out better music signal from phono cartridges.

# Inputs and Outputs

- Input
  - LINE x 3pair
- Output
  - LINE x 1pair
  - BALANCE x 1pair with Polarity Selector

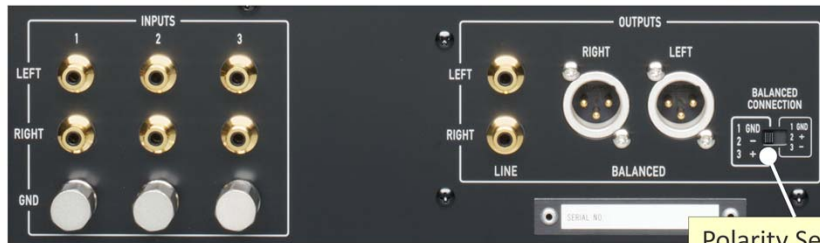
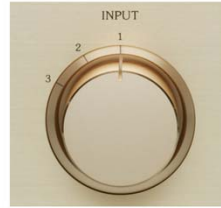

Accuphase Laboratory, Inc.

3

C-37 has 3 inputs for analog players or tonearms, and it can memorize each input's individual function settings.

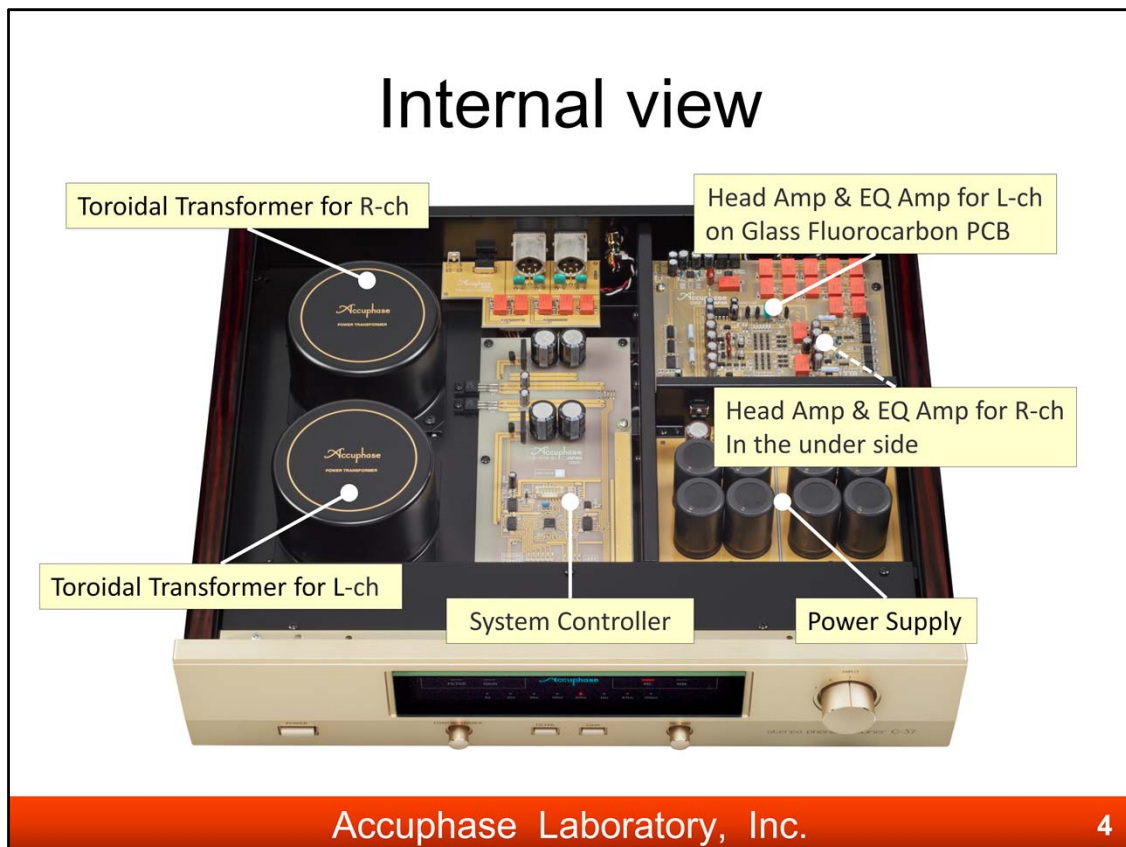

Complete separation design with individual toroidal power transformer and all circuit boards from power source circuit to equalizer amp circuit for left and right channel.

Amplifier circuits are mounting on Glass Fluorocarbon PCB.

C-37 is equipped with Low flux leakage & high-capacity toroidal transformers and power-amplifier-quality strong power circuits consisting of 8 electrolytic capacitors of 15,000 $\mu$ F capacity.

# Evolution from C-27

- Amplifier Configuration

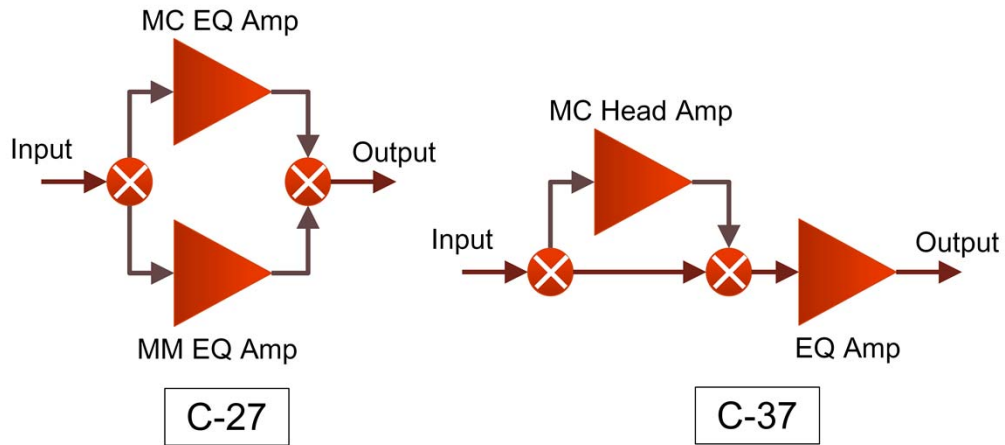

Accuphase Laboratory, Inc.

5

C-27 had separate equalizer amplifiers for MC cartridges and MM cartridges.

C-37 applies the separate configuration MC head amp from equalizer amp. This ensures low noise MC cartridge playback.

# Ultra Low Noise

- 30%(2.5dB) lower than the former model

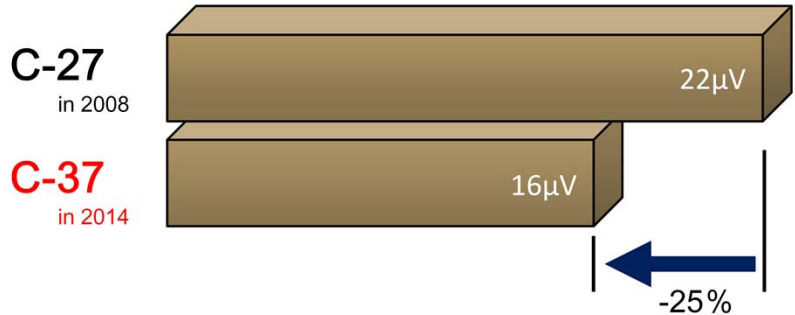

Graph of Actual noise voltage

\* MC position, Gain: 60dB, Input: Short

Accuphase Laboratory, Inc.

6

C-37 succeeded 25% (2.5dB) lower noise than C-27. This noise performance can be said to be a World-Champion-Class quality.

# Super High Precision

- RIAA deviation:  $\pm 0.3\text{dB}$  guarantee

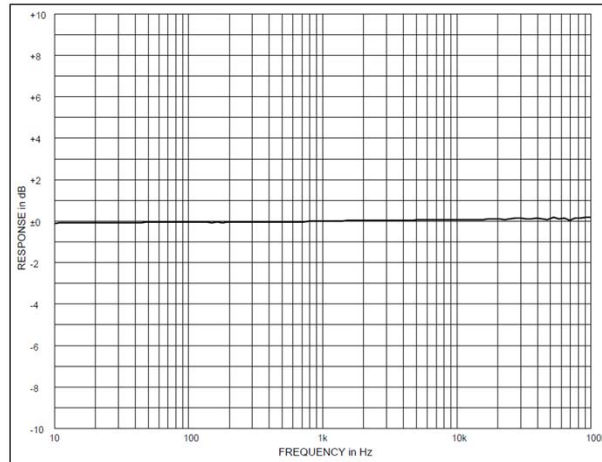

Graph of RIAA deviation

Accuphase Laboratory, Inc.

7

C-37 guarantees RIAA deviation only  $\pm 0.3\text{dB}$  with selected high-precise capacitors and resistors.