

# Accuphase

INTEGRATED STEREO AMPLIFIER

## E-212

● Parallel push-pull output stage delivers quality power: 90 watts per channel into 8 ohms ● Current feedback circuit topology provides outstanding high-range phase characteristics ● Logic-controlled relays for optimum signal routing ● Tone control circuitry ● Option boards allow digital signal input or high-quality analog disc reproduction





**Enjoy high-grade CD reproduction — enabled by option board with high-precision MDS type D/A converter digital input. Power amplifier uses current feedback principle for outstanding high-range phase characteristics and impeccable sound quality. Wide-band power transistors in parallel push-pull configuration deliver 115 watts per channel into 4 ohms or 90 watts per channel into 8 ohms.**

The Accuphase E-200 series of integrated amplifiers is one of our core product ranges, renowned for technological excellence and impeccable quality. The model lineup so far consisted of the E-210, E-210A, and E-211. With the E-212, we are now introducing a further refined version of the E-211, featuring latest circuit design topology and top-notch materials. Sound quality has reached an even higher level than before, presenting a superbly matched blend of performance, features, and musicality.

The power amplifier section of the E-212 boasts excellent phase characteristics and smooth reproduction thanks to the highly renowned current feedback principle. In the output stage, a parallel push-pull arrangement of high-current power transistors designed for demanding audio applications is used, allowing the amplifier to drive even very low impedance loads with ease. The preamplifier section has its own power supply to eliminate interaction with the power amp circuitry. Tone controls, loudness compensator and other features let the user tailor the sound if desired. Up to two tape recorders can be connected for recording and playback, and terminals for two sets of speakers are provided, making the E-212 a flexible and attractive performer. In addition, various options make the E-212 even more versatile. A digital input board with MDS (Multiple Delta Sigma) D/A converter allows direct input of the digital signal for example from a CD player for ultra-pure music reproduction. An option board for reproduction of analog records is also available.

**Parallel push-pull power unit delivers 115 watts/ch into 4 ohms or 90 watts/ch into 8 ohms**

The power transistors used in the output stage are multi-emitter devices designed for audio applications, with optimum frequency response, forward-current transfer ratio linear-

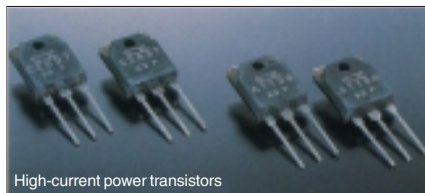

High-current power transistors

ity, and switching performance characteristics. By connecting these devices in a parallel push-pull configuration (Fig. 1), the E-212 achieves low internal impedance. The transistors are mounted to large heat sinks for efficient dissipation of thermal energy. This lavish design results in high-quality power output capabilities rated for 115 watts into 4 ohms, 105 watts into 6 ohms, or 90 watts into 8 ohms per channel.

**Current feedback circuit topology in power amplifier section assures outstanding phase performance in high frequency range**

In the E-212, signal current rather than voltage is used for feedback. Figure 2 shows the

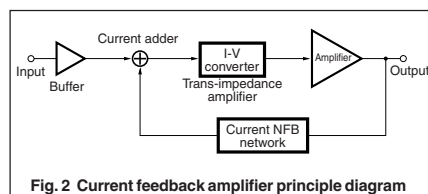

Fig. 2 Current feedback amplifier principle diagram

operating principle of this circuit. At the sensing point of the feedback loop, the impedance is kept low and current detection is performed. An impedance-converting amplifier then converts the current into a voltage to be used as the feedback signal. Since the impedance at the current feedback point (current adder in Figure 2) is very low, there is almost no phase shift. Phase compensation can be kept to a minimum, resulting in excellent transient response and superb sonic transparency. Fig-

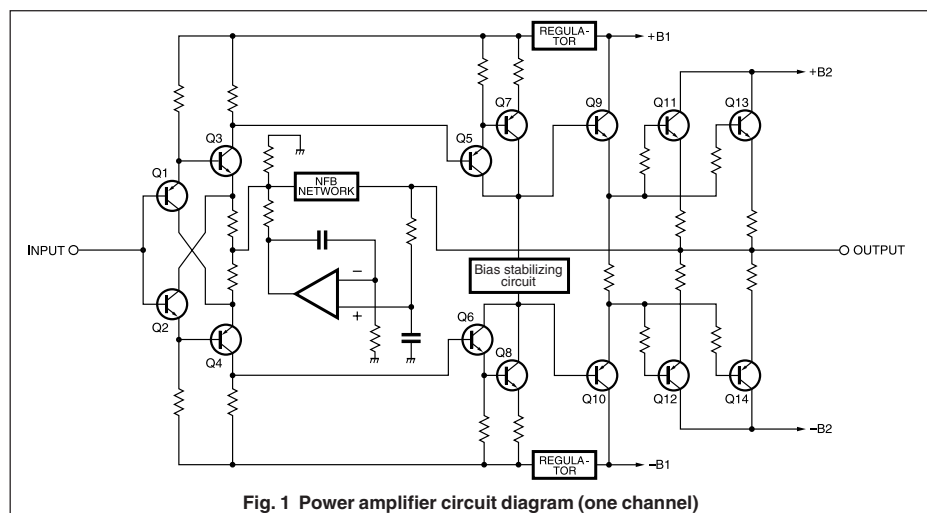

Fig. 1 Power amplifier circuit diagram (one channel)

ure 3 shows frequency response for different gain settings of the current feedback amplifier. The graphs demonstrate that response remains uniform over a wide range.

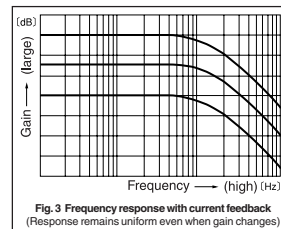
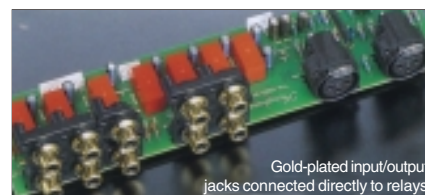

Fig. 3 Frequency response with current feedback (Response remains uniform even when gain changes)

**Highly reliable logic-controlled relays**

To realize the shortest possible signal paths, all switching is performed by logic-controlled relays arranged in an optimized layout. The hermetically sealed relays are high-quality types developed specifically for demanding communication applications. The contacts are twin crossbar types plated with gold for minimum contact resistance and outstanding long-term reliability.



Gold-plated input/output jacks connected directly to relays

**Tone controls use summing active filters for highest sound quality**

The tone control circuitry in the E-212 was specially designed with summing active filters. Figure 4 illustrates the operation principle of this circuit. The flat signal is passed straight through, and only when an adjustment is required, the characteristics are created at F1 and F2 and added to the signal, thereby producing the desired change.

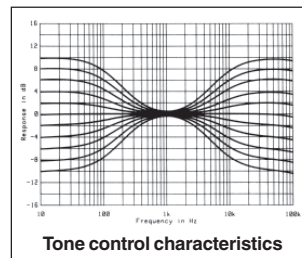

Tone control characteristics

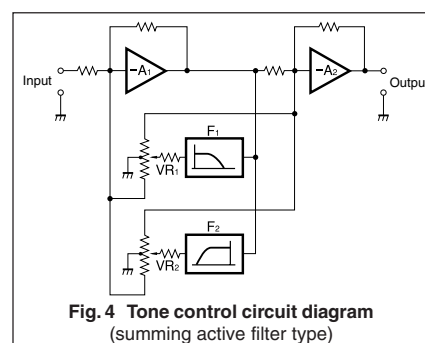

Fig. 4 Tone control circuit diagram (summing active filter type)



This design provides efficient control without degrading signal purity.

### Two pairs of speaker output terminals

The oversize speaker terminals accept even very heavy-gauge speaker cable. The A/B switch-selectable outputs allow driving two pairs of loudspeakers, while the A+B position can be used for bi-wiring where the low and high frequency drivers of a speaker are connected to the amplifier with separate leads.

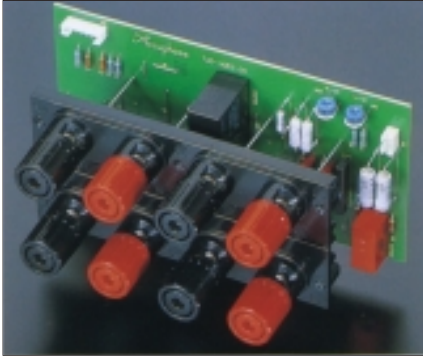

### Analog peak power meters

The large analog power meters use logarithmic compression to cover a wide dynamic range. The peak hold function lets the user easily monitor the output level of the rapidly fluctuating music signal.

### Strong power supply with large power transformer and high filtering capacity

The power supply is the source of energy for an amplifier. The E-212 features a massive 400 VA power transformer and two large electrolytic capacitors rated for 22,000  $\mu\text{F}$  each. This assures ample reserves also for reproduction of demanding bass passages.



High-capacity power transformer and filtering capacitors

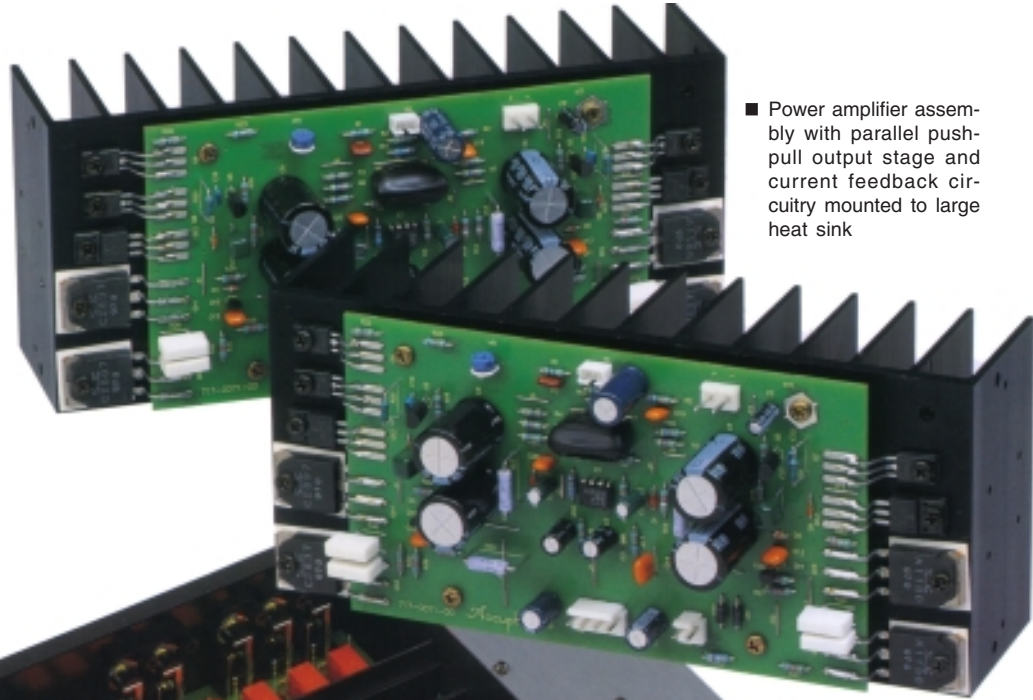

■ Power amplifier assembly with parallel push-pull output stage and current feedback circuitry mounted to large heat sink



■ Supplied remote commander RC-23 Allows volume adjustment and source switching.



## Other Features and Functions

- Option board handles direct digital signal input for high-grade CD reproduction.
- Option board allows analog record reproduction.
- High-quality volume control. Supplied remote commander for volume adjustment and source switching.
- High carbon cast-iron insulator feet for high sound quality.
- Loudness compensator for enhanced bass at low listening levels.

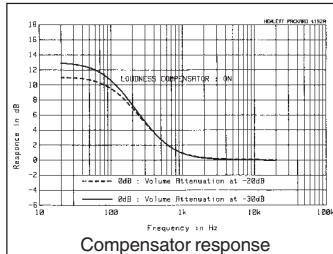

## Option Boards

Three types of option boards are available for the E-212: the Digital Input Board DAC-10, the Analog Disc Input Board AD-9, and the Line Input Board LINE-9. Insert the desired board in the rear-panel option board slot.

- The DAC-10 cannot be used in the models E-407, E-406V, E-306V, E-211, C-265.
- The Analog Disc Input Board AD-10 and the Line Input Board LINE-10 can also be used.



### Digital Input Board DAC-10

This board features an MDS (Multiple Delta Sigma) D/A converter and has inputs for coaxial and optical fiber connections. It can accept the digital output signal from components such as a CD player, MD recorder, DAT recorder, etc. (sampling frequency range 32 - 96 kHz, 24 bits).

### Analog Disc Input Board AD-9

This board contains a high-performance, high-gain phono equalizer.

Internal DIP switches control MM/MC operation, MC input impedance, and subsonic filter on/off.

MM	Gain: 36 dB
	Input impedance: 47 kilohms
MC	Gain: 62 dB
	Input impedance: 10/30/100 ohms (selectable)

### Line Input Board LINE-9

This option board provides an additional set of conventional unbalanced line inputs which can be used to connect a CD player, tuner, or other component with analog output.

## Front panel

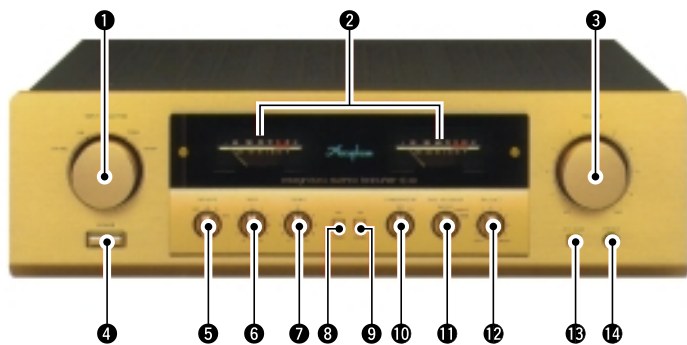

## Rear panel

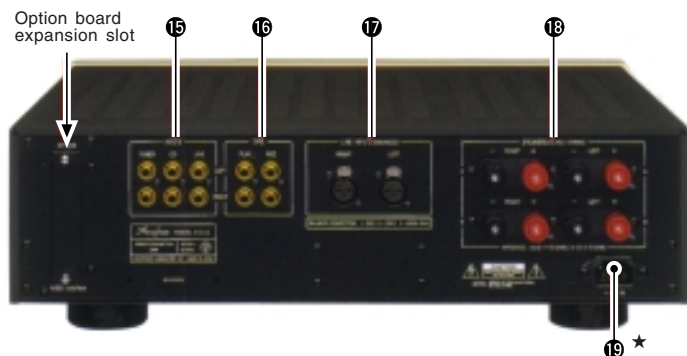

- |   |  |
|---|--|
| <p>1 INPUT SELECTOR<br/>LINE-BAL LINE CD TUNER OPTION</p> <p>2 Peak Power Meters<br/>(Decibel Scale, direct reading)</p> <p>3 VOLUME Control</p> <p>4 POWER Switch</p> <p>5 SPEAKER Selector<br/>OFF A B A+B</p> <p>6 BASS Control</p> <p>7 TREBLE Control</p> <p>8 TONE Controls ON/OFF Button</p> <p>9 STEREO/MONO Button</p> | <p>10 COMPENSATOR Switch</p> <p>11 TAPE RECORDER Selector<br/>REC OFF SOURCE TAPE</p> <p>12 BALANCE Control</p> <p>13 Attenuator Button</p> <p>14 PHONES Jack</p> <p>15 High Level Input Jacks</p> <p>16 PLAY, REC Jacks</p> <p>17 LINE INPUTS (BALANCED)</p> <p>18 SPEAKERS Terminals (A, B)</p> <p>19 AC Power Supply Connector*</p> |
|---|--|

### Remarks

- \* This product is available in versions for 120/230 V AC. Make sure that the voltage shown on the rear panel matches the AC line voltage in your area.
- \* The shape of the AC inlet, and plug of the supplied power cord depends on the voltage rating and destination country.

- Supplied accessories:
- AC power cord
  - Remote commander RC-23

## GUARANTEED SPECIFICATIONS

[Guaranteed specifications are measured according to EIA standard RS-490.]

- **Continuous Average Output Power** 115 watts per channel into 4 ohms  
(both channels driven, 20 - 20,000 Hz)  
105 watts per channel into 6 ohms  
90 watts per channel into 8 ohms
- **Total Harmonic Distortion** 0.04%, with 4 to 16 ohms load  
(both channels driven, 20 - 20,000 Hz)
- **Intermodulation Distortion** 0.01%
- **Frequency Response** HIGH LEVEL INPUT: 20 - 20,000 Hz +0, -0.2 dB  
(at rated continuous average output)
- **Damping Factor** 100 (with 8-ohm load, 50 Hz)
- **Input Sensitivity, Input Impedance**

Input	Sensitivity		Input impedance
	For rated output	For 1 W output (EIA)	
HIGH LEVEL INPUT	213 mV	22.5 mV	20 kΩ
BALANCED INPUT	213 mV	22.5 mV	40 kΩ

- **Gain** HIGH LEVEL INPUT → OUTPUT: 42 dB  
(UNBALANCED/BALANCED)
- **Tone Controls** Turnover frequency and adjustment range  
BASS: 300 Hz ±10 dB (50 Hz)  
TREBLE: 3 kHz ±10 dB (20 kHz)
- **Loudness Compensation** +6 dB (200 Hz) (Volume control setting -30 dB)
- **Attenuator** -20 dB
- **Signal-to-Noise Ratio**

Input	Input shorted, IHF-A weighting S/N ratio at rated input	S/N ratio (EIA)
HIGH LEVEL INPUT	110 dB	81 dB
BALANCED INPUT	92 dB	81 dB

- **Power Level Meters** Logarithmic compression, peak reading meters with a dB scale calibrated for an 8-ohm load
- **Load Impedance** 4 - 16 ohms
- **Stereo Headphones** Suitable impedance: 8 - 100 ohms
- **Power Requirements** 120 V/230 V (Voltage as indicated on rear panel)  
AC, 50/60 Hz
- **Power Consumption** 30 watts idle  
220 watts in accordance with IEC-65
- **Maximum Dimensions** Width 475 mm (18-11/16")  
Height 150 mm (5-7/8")  
Depth 422 mm (16-5/8")
- **Weight** 18.9 kg (41.6 lbs) net  
23.0 kg (50.7 lbs) in shipping carton
- **Supplied Remote Commander RC-23** Remote control principle: Infrared pulse  
Power supply: 3 V DC (IEC R6 batteries × 2)  
Dimensions: 45 (W) × 136 (H) × 18 (D) mm  
Weight: 85 g (including batteries)