

Integrated Stereo Amplifier E-470



Accuphase Laboratory, Inc.

1

E-470 is a succession model of E-460 and flag ship integrated Class-AB amplifier of Accuphase. Technical high lights of E-470 are ULTRA LOW NOISE and SUPER HIGH DAMPING-FACTOR. They were inherited from our 40 years anniversary model C-3800 and A-200.

Output power

- Class-AB 290W / channel into 4 ohm

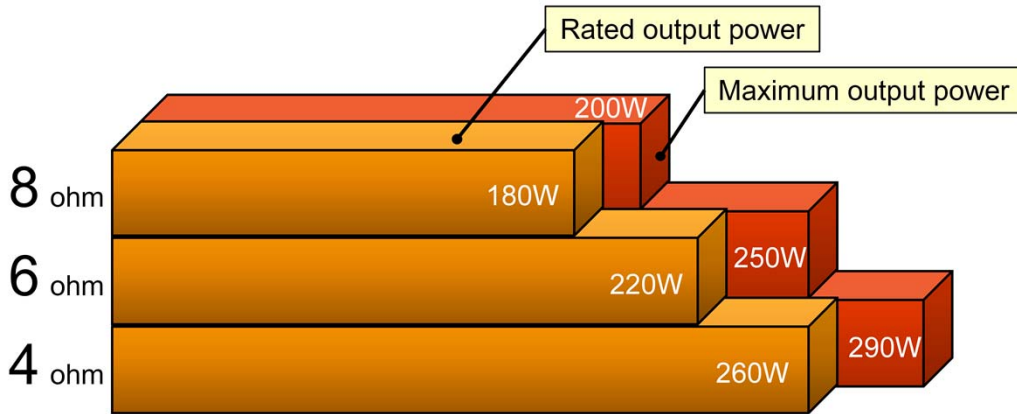

Graph of output power

Accuphase Laboratory, Inc.

2

The continuous average output power is 180W into 8 ohm load.

However E-470 has bigger headroom for maximum output power. It is 200W into 8 ohm and 290W into 4 ohm.

E-470 is the high-power integrated amplifier.

Ultra Low Noise

- Lower noise than the former model E-460
 - Actual noise voltage of speaker output: $34\mu\text{V}$
@Volume position: -30dB

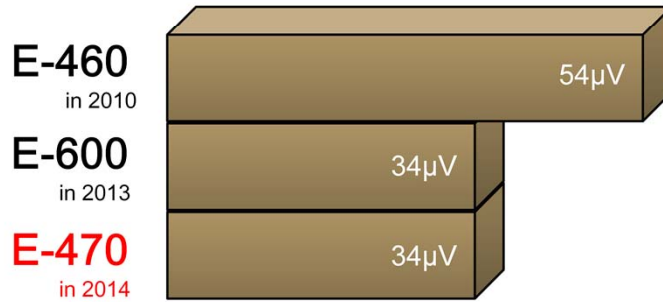

Graph of Actual noise voltage

Accuphase Laboratory, Inc.

3

E-470 is the remarkably low noise amplifier exceeding E-460.

E-470 has $34\mu\text{V}$ of actual noise voltage.

This is 63%(-4dB) of the former model E-460.

Technology for ultra low noise

- AAVA re-designed for low noise
 - Paralleled V-I converter in larger two units
 - Low-impedance feedback network I-V converter

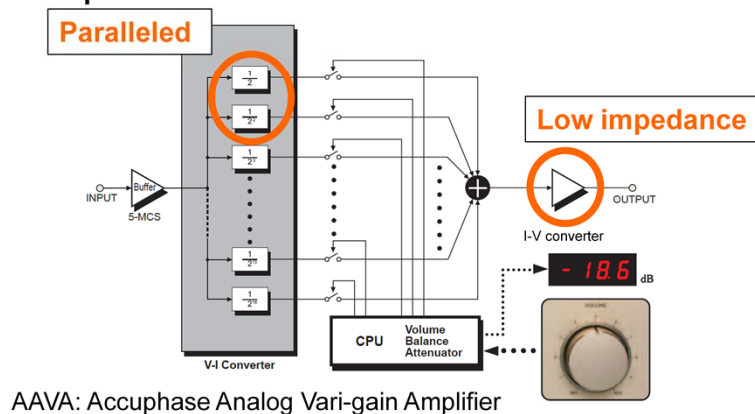

Accuphase Laboratory, Inc.

4

AAVA in E-470 achieves low noise by paralleled V-I converter in larger two units and low-impedance feedback network on I-V converter.

Thanks to these technologies, noise level at AAVA has been improved by 2.5dB lower than E-460.

Technology for ultra low noise

- Power amplifier re-designed for low noise
 - Low-impedance feedback network

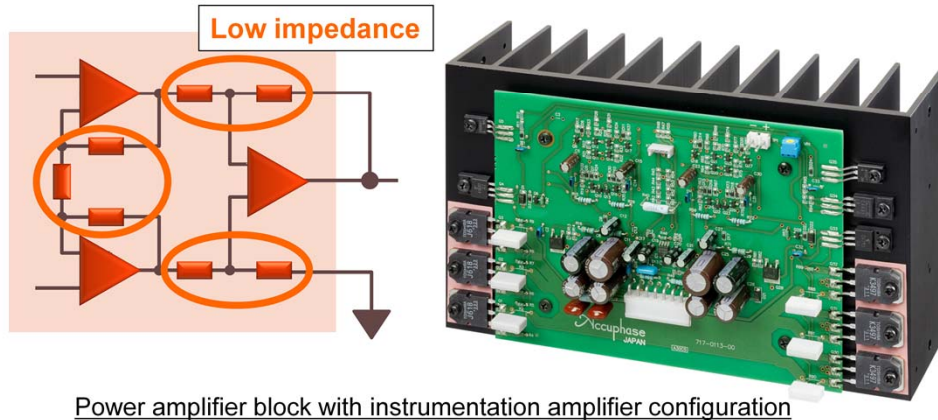

Power amplifier block with instrumentation amplifier configuration

Accuphase Laboratory, Inc.

5

E-470 applies Low-impedance feedback network in power amplifier section.

Thanks to this technology, noise level at power amplifier has been improved by 1.5dB lower than E-460.

Super high Damping-Factor

- 2.5 times higher than E-460
 - Damping Factor: 500 guaranteed

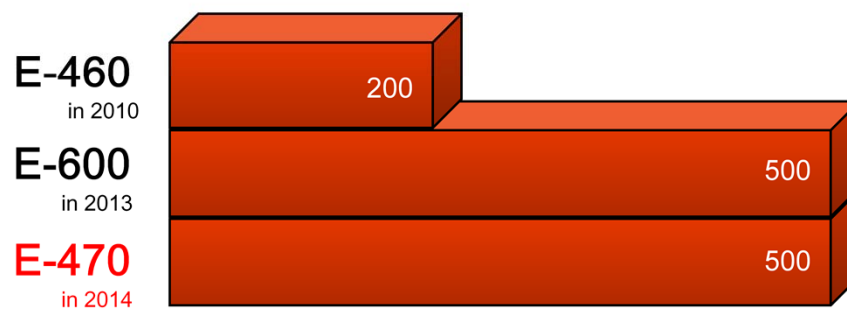

Graph of guaranteed Damping-Factor

Accuphase Laboratory, Inc.

6

E-470 achieves 500 of Damping-Factor.

It is 2.5 times higher than the former model E-460 and equal to E-600.

500 of DF is guaranteed spec. In actuality, DF of E-470 is about 700.

*Damping-Factor, DF:

An index of speaker driving ability. Higher Damping-Factor amplifier has higher speaker driving ability.

$DF = 8 \text{ ohm} / \text{Output-impedance}$

Technology for high DF

- Balanced Remote-sensing
 - Feedback from speaker terminal proximity
 - Signal-line and GND-line sensing

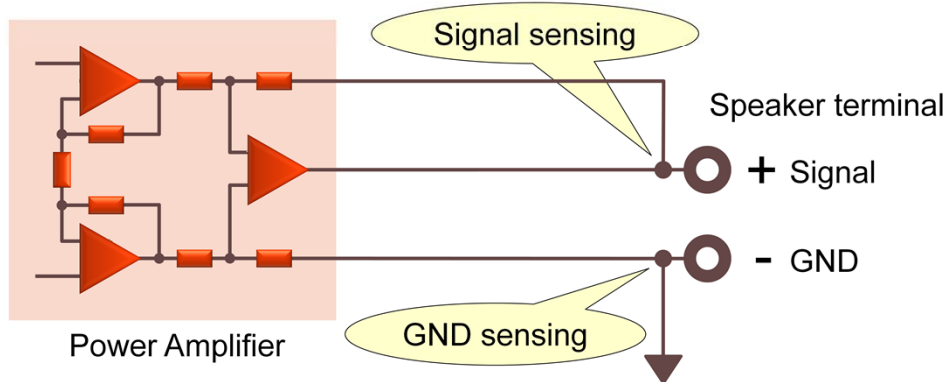

Accuphase Laboratory, Inc.

7

Remote-sensing is the technique to lower output impedance of amplifier by the negative feedback with signal sensing from close up the speaker terminals.

Balanced Remote-sensing is the technique to make impedance even lower by GND sensing and the negative feedback of GND level with adding the signal sensing.

Not only Damping-factor is improved but also Total Harmonic Distortion and Intermodulation Distortion get better by Balanced Remote-sensing.

Balanced Remote-sensing was not applied in the former model E-460.

Technology for high DF

- Speaker protection equipped with MOSFET
- Using very low resistance components
- Short signal path configuration



Accuphase Laboratory, Inc.

8

Mechanical relay is the most common for speaker protection as output switch.

However E-470 employs MOSFET switch instead of mechanical relay.

It is because MOSFET switch is more reliable and the contact resistance is much lower.

Damping-Factor, reliability and sound quality are improved thanks to MOSFET switch.

Some other very low resistance components which are chosen for E-470 are large speaker terminal, low resistance wire coil and so on.

Making signal path thick and short attains having low impedance.

Further more ...

- Ready for the option board DAC-40
 - Sampling frequency on the front display



- Balanced Pre-Output and Power-Input



Accuphase Laboratory, Inc.

9

E-470 accepts the digital input board DAC-40. You can see the figure of sampling frequency input into DAC-40 on the front panel display. Balanced-type input and output are additionally equipped as Pre-Output and Power-Input.