

# Accuphase

STEREO POWER AMPLIFIER

## P-7100

- Powerful 11-parallel push-pull output stage in each channel delivers linear power into loads as low as one ohm
- Instrumentation amplifier type design of amplification stages
- Further refined MCS+ circuit topology
- Current feedback circuit combines excellent sound quality with total operation stability
- Bridged connection mode allows upgrading to true monophonic amplifier
- 4-step gain control
- Massive Super Ring toroidal transformer rated for 1.5 kVA





**Impressive power amplifier capable of delivering 1000 watts × 2 into 1 ohm – Amplification stages feature fully balanced signal paths as found in high-quality instrumentation amplifiers. Further refined MCS+ topology and current feedback design result in even better S/N ratio, distortion, and other performance parameters. Massive, high-efficiency 1.5 kVA toroidal transformer and 11-parallel push-pull arrangement of high-power transistors deliver enormous amounts of linear power into ultra-low loads down to one ohm.**

The P-7100 is a successor to the highly regarded P-7000, inheriting its general design policy and major features while realizing further improvements in various aspects. A major new highlight is the overall "instrumentation amplifier" configuration, which allows fully balanced signal transmission in all stages of the amplifier. In addition, the power amplifier section employs MCS+, an improved version of the innovative Multiple Circuit Summing principle developed by Accuphase. In conjunction with the famous current feedback topology, this provides further improved performance characteristics. Only strictly selected high-quality parts and materials are used throughout, and the output of the amplifier is designed to achieve very low impedance and constant drive voltage.

In the output stage, 11 pairs of high-power transistors with a rated collector dissipation of 150 watts are arranged in a parallel push-pull configuration for each channel. The devices are mounted to large heat sinks on both sides of the main chassis for efficient dissipation of thermal energy generated during operation. As a result, the amplifier is capable of delivering power in a linear progression down to an ultra-low load impedance of one ohm. Even speakers with very low impedances as well as speakers whose impedance fluctuates drastically can be driven with ease. By using the P-7100 in bridged mode, it is possible to create a monophonic amplifier with even higher power. This performance is sustained by a massive Super Ring toroidal transformer housed in an aluminum enclosure with excellent heat dissipation characteristics. The transformer is rated for 1.5 kVA, and is coupled with two large filtering capacitors rated for 56,000 µF each. This allows the amplifier to meet even the most demanding and rapidly fluctuating power requirements with ease.

The input stage features another Accuphase innovation called MCS+ (Multiple Circuit Summing) which helps to minimize noise. The material used for printed circuit boards has a decisive influence not only on electrical characteristics but also on the sonic end result. The P-7100 employs Teflon boards with extremely low dielectric constant and low loss. The copper foil side of PCBs and all input and output terminals as well as all major signal carrying points are gold plated. Balanced inputs help to shut out external noise. The combination of outstanding circuit design with top-quality materials and parts produces music of unsurpassed purity that immediately captures and enchants the listener. Hearing is believing.

■ **11-parallel push-pull power unit delivers guaranteed linear power output of 1000 watts into 1 ohm (music signals only), 500 watts into 2 ohms, 250 watts into 4 ohms and 125 watts into 8 ohms**

The output stage uses high-power transistors with a rated collector dissipation of 150 watts and collector current of 15 amperes. These devices boast excellent frequency response, current amplification linearity, and switching characteristics.

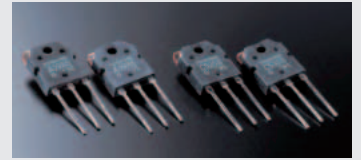

High-power transistors

■ **Printed circuit boards made from Teflon with low dielectric constant and low loss**

\* Teflon is a registered trademark of DuPont USA.

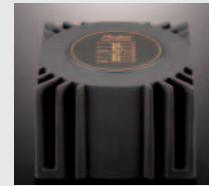

Toroidal transformer



Filtering capacitors

■ **Robust power supply with Super Ring toroidal transformer and high filtering capacity**

The P-7100 features a massive toroidal power transformer with a maximum rating of 1.5 kVA, and two large electrolytic capacitors rated for 56,000 µF each, specially selected for optimum sound quality.

■ **Bridged connection allows upgrading to a true monophonic amplifier with 2000 watts into 2 ohms (music signals only), 1000 watts into 4 ohms, and 500 watts into 8 ohms**

Bridged connection results in a monophonic amplifier with four times the power output than during stereo operation. This gives effortless dynamic power.

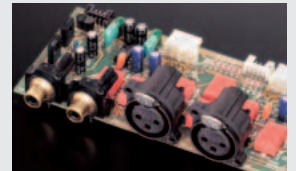

Unbalanced/balanced input connectors

■ **Balanced inputs prevent externally induced noise**

■ **4-step gain selector minimizes residual noise (MAX, -3 dB, -6 dB, -12 dB)**

■ **PCB copper foil and all major signal path components are gold-plated**

■ **Mode selector makes it easy to switch between dual mono, stereo, or bridged operation**



Gold-plated parts



Gain selector

■ **Large direct-reading analog power meters with meter on/off button**

■ **Input selector button (balanced/unbalanced) on front panel**

■ **Oversize speaker terminals accept also Y lugs**



Meter and input selector buttons

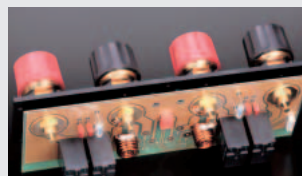

Large speaker terminals

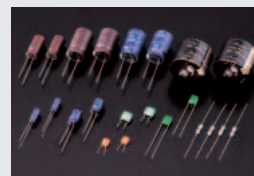

Highly reliable parts selected for sound quality

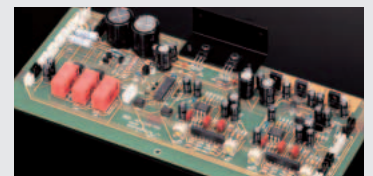

Assembly with meter and protection circuitry

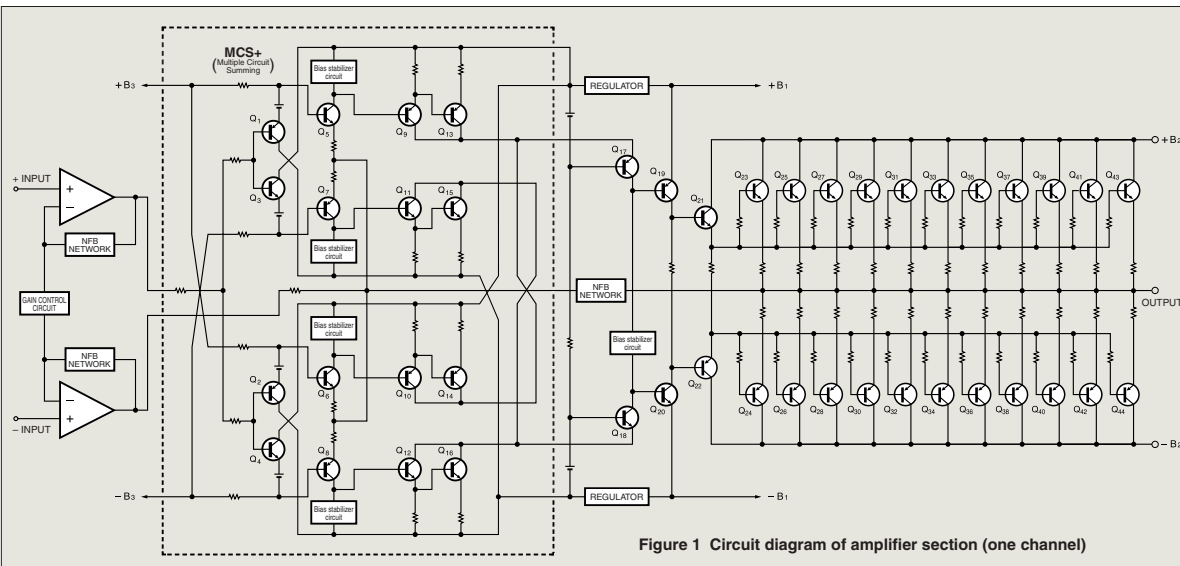

Figure 1 Circuit diagram of amplifier section (one channel)

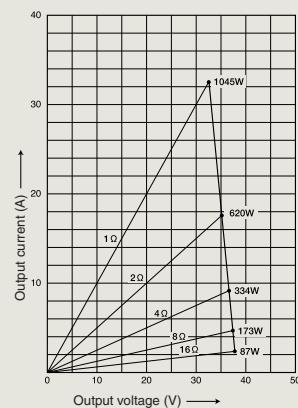
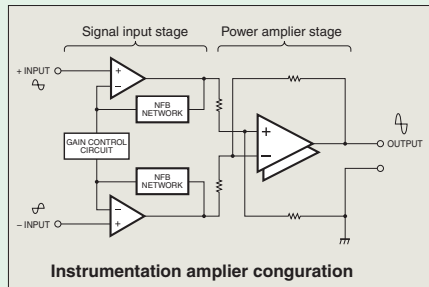

Figure 2 Load impedance vs. output power (output voltage/output current)  
\* 1-ohm operation possible with music signals only

# Instrumentation Amplifier Principle and Further Refined MCS+ Topology

## Instrumentation amp configuration allows fully balanced signal paths

The amplification sections of the P-7100 feature the newly adopted "instrumentation amplifier" principle whereby all signal paths from the inputs to the power amp stage are fully balanced. This results in excellent CMRR (Common Mode



Rejection Ratio) and minimal distortion. Another significant advantage is that external noise and other external influences are virtually shut out. The result is a drastic improvement in power amplifier operation stability and reliability.

- Power amplifier assembly with 11 parallel push-pull transistor pairs per channel mounted directly to large aluminum diecast heat sinks, instrumentation amplifier and MCS+ circuitry, and current feedback amplifier

## Further refined MCS+ topology for even lower noise

Accuphase's original MCS (Multiple Circuit Summing) principle uses a number of identical circuits connected in parallel to achieve superior performance characteristics. MCS+ is a further refined

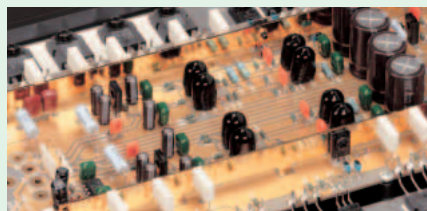

version of this approach. Improvements in the bias circuitry of the input-stage buffer amplifier result in greater stability. This in turn makes it possible to extend the parallel operation approach to the class-A drive stage of the current/voltage converter, thereby further lowering the noise floor.

## Current feedback circuit topology assures excellent phase characteristics in high range

In the P-7100, the signal current rather than the more conventionally used voltage is used for feedback. Since the impedance at the current feedback point is very low, there is almost no phase shift. Phase compensation can therefore be kept at a minimum. A slight amount of NFB results in maximum improvement of circuit parameters.

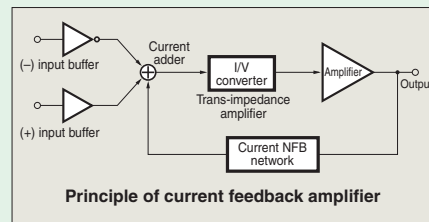

### Connection example for bi-amping setup

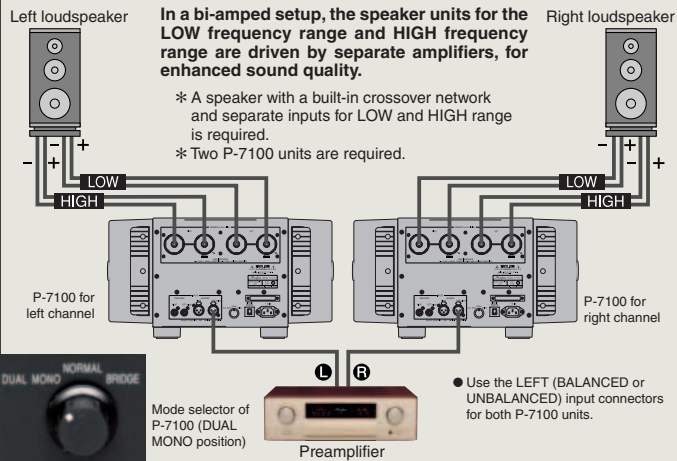

### Connection example for bridged setup

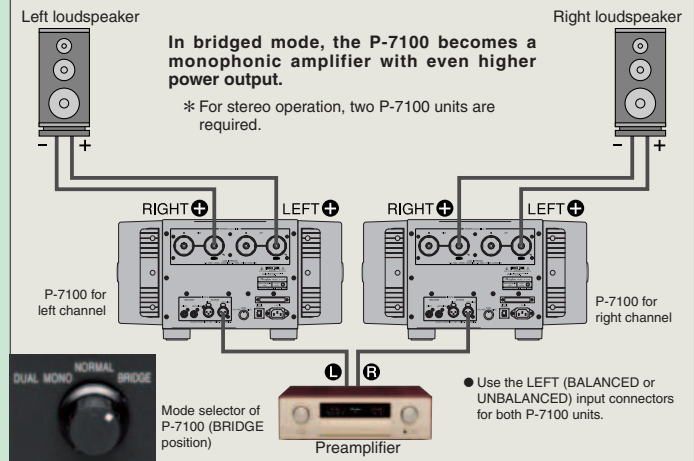

### Front Panel

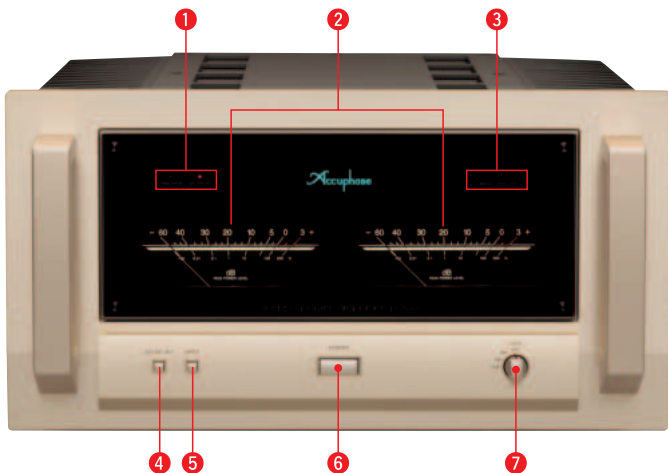

### Rear Panel

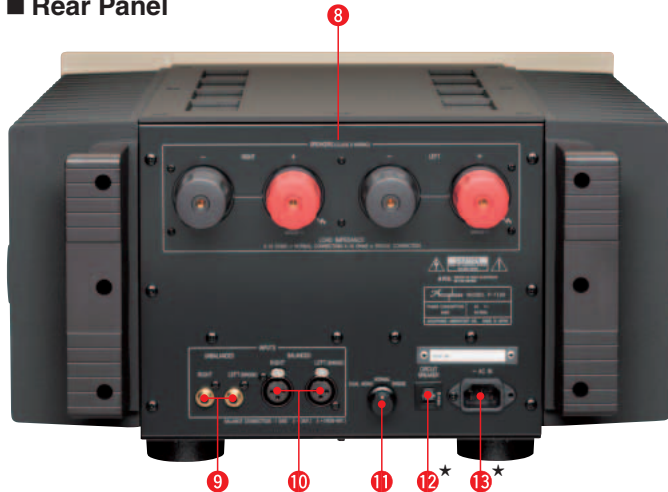

- 1 Input type indicators
- 2 Power meters (dB and % scale)
- 3 Bridged mode indicator
- 4 Meter operation/illumination switch
- 5 Input selector button  
BALANCED UNBALANCED
- 6 Power switch
- 7 Gain selector  
MAX -3 dB -6 dB -12 dB
- 8 Speaker terminals
- 9 Unbalanced inputs
- 10 Balanced inputs  
① Ground ② Inverted (-)  
③ Non-inverted (+)
- 11 Mode selector  
DUAL MONO NORMAL BRIDGE
- 12 Circuit breaker\*
- 13 AC power supply connector\*

#### Remarks

- \* This product is available in versions for 120/230 V AC. Make sure that the voltage shown on the rear panel matches the AC line voltage in your area.
- \* The shape of the AC inlet and plug of the supplied power cord as well as the circuit breaker current rating depend on the voltage rating and destination country.

### Parallel drive of output devices

Semiconductor devices for high frequency applications usually employ a multi-chip design where a number of small transistors or FETs are connected in parallel. This approach allows reducing inherent impedance and residual noise as compared to single device operation. In other words, linearity is improved. In physical terms, increasing the surface area of the chip prevents spot overheating by providing better heat dissipation, resulting in more stable operation.

Parallel connection in the output stage of the P-7100 uses a similar principle for distributing the current, which lets the amplifier easily deal with sudden demands for high current, such as caused by pulsive source signals. However, a parallel circuit as implemented by Accuphase is much more than a simple physical connection. Accuphase's extensive know-how gained through many years of intensive research and experimentation is in evidence here. Careful control of temperature characteristics, current matching of individual devices, and many other advanced measures are implemented. The overall result is minimized distortion at low currents and improved S/N ratio, which manifests itself as dramatically improved clarity and transparency at low listening levels. Ample current reserves make it possible to drive even extremely low loads with effortless authority. No-holds-barred performance and superb sound are the hallmarks of Accuphase amplifiers.

### P-7100 Guaranteed Specifications

[Guaranteed specifications are measured according to EIA standard RS-490.]

- **Continuous Average Output Power (20 - 20,000 Hz)**
  - Stereo operation (both channels driven)
    - 1,000 watts per channel into 1 ohm (\*)
    - 500 watts per channel into 2 ohms
    - 250 watts per channel into 4 ohms
    - 125 watts per channel into 8 ohms
  - Monophonic operation (bridged connection)
    - 2,000 watts into 2 ohms (\*)
    - 1,000 watts into 4 ohms
    - 500 watts into 8 ohms
- Note: Load ratings marked (\*) apply only to operation with music signals.
- **Total Harmonic Distortion**
  - Stereo operation (both channels driven)
    - 0.05% with 2 ohm load
    - 0.03% with 4 to 16 ohm load
  - Monophonic operation (bridged connection)
    - 0.03% with 4 to 16 ohm load
- **Intermodulation Distortion** 0.01%
- **Frequency Response**
  - At rated output: 20 - 20,000 Hz +0, -0.2 dB
  - At 1 watt output: 0.5 - 160,000 Hz +0, -3.0 dB
- **Gain** 28.0 dB (with GAIN selector at MAX)
- **Gain selection** MAX, -3 dB, -6 dB, -12 dB
- **Output Load impedance**
  - Stereo operation: 2 to 16 ohms
  - Monophonic operation: 4 to 16 ohms
- [With music signals only, 1-ohm loads are permissible for stereo operation and 2-ohm loads for monophonic operation.]
- **Damping Factor** 300
- **Input Sensitivity (with 8-ohm load)**
  - Stereo operation
    - 1.26 V for rated output
    - 0.11 V for 1 watt output
  - Monophonic operation
    - 2.52 V for rated output
    - 0.11 V for 1 watt output
- **Input Impedance**
  - Balanced: 40 kilohms
  - Unbalanced: 20 kilohms
- **Signal-to-Noise Ratio**
  - 122 dB (GAIN selector in MAX position)
  - 127 dB (GAIN selector in -12 dB position)
- **Output Level Meters** Logarithmic scale, with defeat switch -60 dB to +3 dB (indication in %)
- **Power Requirements** AC 120 V / 230 V, 50 / 60 Hz (Voltage as indicated on rear panel)
- **Power Consumption**
  - 135 watts idle
  - 945 watts in accordance with IEC-60065
- **Maximum dimensions**
  - 465 mm (18-5/16") width
  - 258 mm (10-3/16") height
  - 545 mm (21-7/16") depth
- **Mass**
  - 49.0 kg (108.0 lbs.) net
  - 58.0 kg (127.9 lbs.) in shipping carton

### Supplied accessory

- AC power cord



ACCUPHASE LABORATORY, INC.

F0605Y PRINTED IN JAPAN 851-0157-00 (AD1)