

Accuphase

STEREO POWER AMPLIFIER

STEREO PREAMPLIFIER

# P-11 / C-11



The home is no longer simply a place for everyday living, it is also a stage on which we actively enrich our personal sensibility. Our rooms are filled with self-expressive items of leisure. In choosing products and coordinating colors, we find a challenging opportunity to express our individual taste. Sophisticated design is important, but, at the same time, demands placed on quality and performance are higher than ever. For the discerning music listener, only the best will do.

The Accuphase separate-type amplifiers P-11 and C-11 were created to match this new lifestyle both in appearance and in internal qualities. The front panel with the traditional Accuphase champagne gold finish is supported by solid metal end blocks, which creates a perfect blend of weight and lightness.

Internally, these components fully reflect Accuphase's impressive technological resources.

The series 11 is designed for music reproduction of the highest order. Individually and together, these components are bound to open up new horizons in audio enjoyment.

P-11 Front Panel/Rear Panel

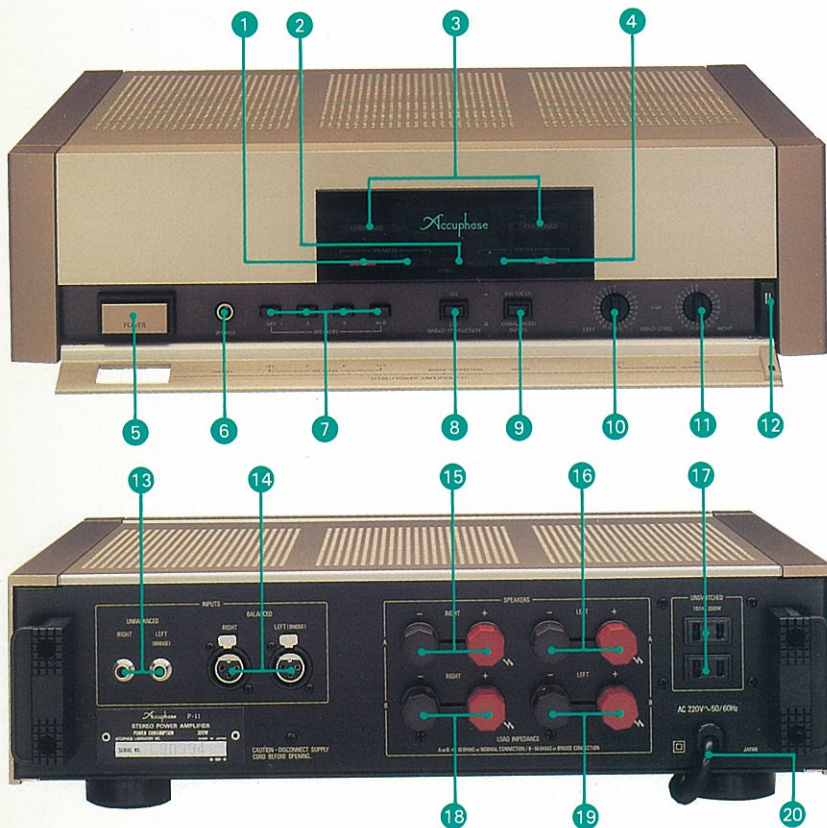

#### STEREO POWER AMPLIFIER P-11

- 1 Speaker indicator SYSTEM A, SYSTEM B
- 2 Bridge connection indicator
- 3 Overload indicator
- 4 Unbalanced/balanced indicator BAL, UNBAL
- 5 POWER switch
- 6 Headphone jack
- 7 SPEAKERS selector OFF, A, B, A+B
- 8 BRIDGE CONNECTION switch ON/OFF
- 9 INPUT selector BALANCED/UNBALANCED
- 10 Left-channel and bridge connection (mono) INPUT LEVEL control 1-dB steps
- 11 Right-channel INPUT LEVEL control 1-dB steps
- 12 Sub-panel magnet lock
- 13 Input jack (unbalanced-20 kilohms)  
Left input is used for bridged connection (mono)
- 14 Cannon-type input connectors (balanced-40 kilohms)  
Left input is used for bridged connection (mono)
- 15 Speaker A right-channel output terminals
- 16 Speaker A left-channel output terminals
- 17 AC outlet (unswitched)\*
- 18 Speaker B right-channel output terminals
- 19 Speaker B left-channel output terminals
- 20 Power cord

#### STEREO PREAMPLIFIER C-11

- 1 Input selector LINE-1, LINE-2, LINE-3, TUNER, CD, LINE-BAL, TAPE-1, TAPE-2, AD, CD-BAL
- 2 Input position indicator (5 x 7 dot LED panel)
- 3 Function indicator LEDs TONE: ON/OFF, REC OUT: ON/OFF, SUBSONIC: ON/OFF, COMPENSATOR: ON/OFF, STEREO/MONO, MM/MC
- 4 Remote control sensor
- 5 ATT (attenuator)
- 6 VOLUME control
- 7 POWER switch
- 8 Headphone jack

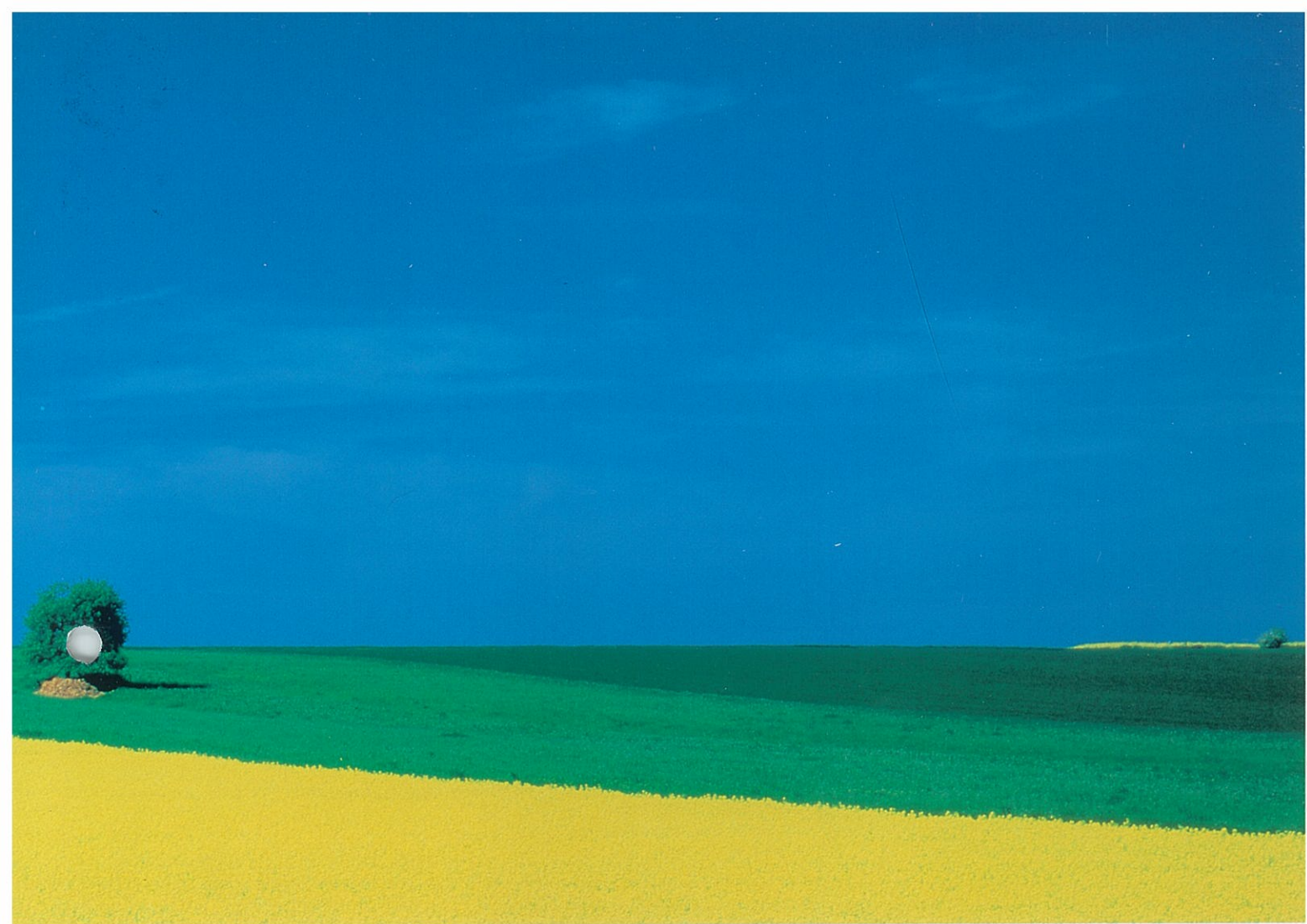

### C-11 Front Panel/Rear Panel

- 1 OUTPUT selector  
OFF, 1&2, 1, 2
- 2 BASS control
- 3 TREBLE control
- 4 TONE (tone control ON/OFF) switch
- 5 REC SELECTOR  
LINE-BAL, LINE-3, LINE-2, LINE-1, TUNER, REC OFF, CD,  
CD-BAL, AD
- 6 TAPE COPY switch  
1→2, OFF, 2→1
- 7 SONIC filter switch  
2 - 12dB/oct
- 8 COMP (loudness compensator) switch
- 9 MONO/STEREO selector
- 10 AD (phone stage gain) switch
- 11 BALANCE control
- 12 Sub-panel magnet lock
- 13 Ground terminal
- 14 AD (analog disc) input jacks
- 15 CD (unbalanced) input jacks
- 16 Tuner input jacks
- 17 LINE-1 input jacks
- 18 LINE-2 input jacks
- 19 LINE-3 input jacks
- 20 TAPE-1 input jacks
- 21 TAPE-1 recording output jacks
- 22 TAPE-2 input jacks
- 23 TAPE-2 recording output jacks
- 24 Output jacks (unbalanced/1 ohm)
- 25 Output jacks (unbalanced/1 ohm)
- 26 AC outlet (switched)\*
- 27 AC outlet (unswitched)\*
- 28 CD (Line) balanced input connectors  
XLR-3-31 type (1: GND, 2: Inverted 3: Non-inverted)  
for XLR-3-12C type plug
- 29 Line (CD) balanced input connectors
- 30 Balanced output connectors  
XLR-3-32 type (1: GND, 2: Inverted 3: Non-inverted)  
for XLR-3-11C type plug
- 31 Power cord

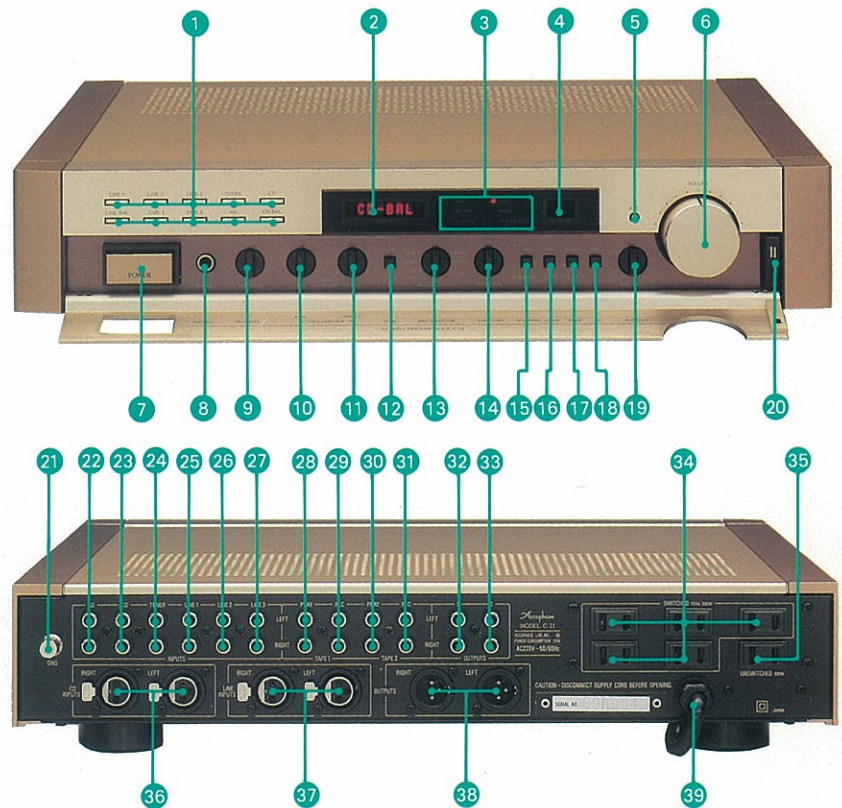

Remarks:  
\* These SWITCHED and UNSWITCHED outlets may not be supplied depending on the safety standards or regulations applicable in the particular country to where the unit is destined.



**P-11** Ample power output (120 watts per channel into 8 ohms) with low-impedance drive capability. Professional balanced inputs. Mono operation mode with 340 watts into 8 ohms.

The task of a power amplifier is to faithfully and reliably deliver driving energy to the speakers in exact proportion to the input signal. As music is never uniform, this input signal is subject to drastic changes from one minute to the next, following the transients in the music. If the speaker were a purely resistive load, the task of the amplifier would be quite easy and straightforward. However, as the impedance of a loudspeaker fluctuates considerably depending on the frequency of the signal, the speaker also presents a complex reactive load to the amplifier. In order to be able to supply sufficient energy in linear fashion, an amplifier must be able to deliver high output power also into very low impedances. This is called "low-impedance drive capability."

The power amplifier P-11 of the new Accuphase series was developed with this fact in mind. It is designed not only for outstanding frequency response, minimum distortion and high S/N ratio, but also for superior low-impedance drive capability. Employing a large power transformer and an output stage with triple parallel push-pull design, the P-11 is rated for 120 watts per channel into 8 ohms, 170 watts per channel into 4 ohms, and a full 200 watts per channel into 2 ohms. Original Accuphase technology is in evidence throughout, such as the MOS-FET final pre-driver stage equivalent to class A operation, the predriver circuit designed as a totally symmetrical push-pull differential amplifier, and the direct-coupled input with DC servo configuration.

The P-11 can also be used in a totally balanced bridged configuration, resulting in a monophonic power amplifier with an impressive output of 340 watts into 8 ohms. The first-rate performance and simple and refined design of the P-11 perfectly match the preamplifier C-11. Together this new pair of components brings the music alive as never before.

**1** Huge-power transformer and triple-parallel push-pull design yield ample power with 120 watts/channel into 8 ohms and 170 watts/channel into 4 ohms.

Fig. 1 shows the circuit diagram of this amplifier. The output stage is formed by six large-power transistors ( $Q_{17} - Q_{22}$ ) with a  $P_C$  (maximum heat dissipation) of 130 watts each, resulting in a total maximum heat dissipation of 780 watts. These devices are arranged in a triple-parallel push-pull configuration and deliver 120 watts per channel into 8 ohms and 170 watts per channel into 4 ohms. Even with loads as low as 2 ohms, the amplifier can supply a full 200 watts per channel. This amazing capacity is made possible by the amply dimensioned power supply featuring a large toroidal power transformer with highly stable operation that remains unaffected by voltage fluctuations. Even at high output power levels, this power supply still has adequate reserves.

To drive the output devices, high signal voltages are required and the output impedance must be low. The drive stage therefore requires power amplification devices which can handle high voltages and have linear characteristics. The P-11, as can be seen from Fig. 1, excels in this regard also, since it uses Accuphase original power MOS-FET circuitry which ensure perfect drive characteristics free from switching distortion.

**2** Bridged operation creates a purely monophonic power amplifier with 340 watts into 8 ohms and 400 watts into 4 ohms.

"Bridged operation" refers to a special connection in which the two stereo sections of an amplifier are driven by an identical signal with opposite phase. By connecting the loudspeaker

across both sections, twice the output power of stereo operation can be obtained. This amounts to using the two amplifier sections in a push-pull configuration. In conventional bridged designs, a phase inverting circuit is inserted in the input of one amplifier section, which can lead to a degradation of signal quality. In the P-11, on the other hand, the polarity of the differential input circuits is used in an ingenious design, permitting a simple switching arrangement without the need for any additional amplifier stages. Rated output power of the P-11 in bridged operation is 340 watts into 8 ohms and 400 watts into 4 ohms, for a further increase in sheer dynamic impact and presence.

**3** Cascade FET input circuit ensures optimum performance regardless of input impedance.

The voltage amplification stage consists of  $Q_6$  and  $Q_7$  (Fig. 1), which operate as a differential amplifier stage. This stage is preceded by a buffer stage ( $Q_1 - Q_5$ ) to shut out any adverse influence from the preamplifier and input level controls etc. The FET cascode connection principle has superior high-frequency characteristics and remains highly stable even if the input impedance fluctuates considerably.

**4** Separate left/right power supplies for input buffer, differential input and drive stages ensure optimum stereo imaging

The gain of a power amplifier is about 30dB, which makes it less susceptible to adverse influences from using a common power supply than, for example, a high-gain preamplifier. However, to ensure an ample safety margin, the

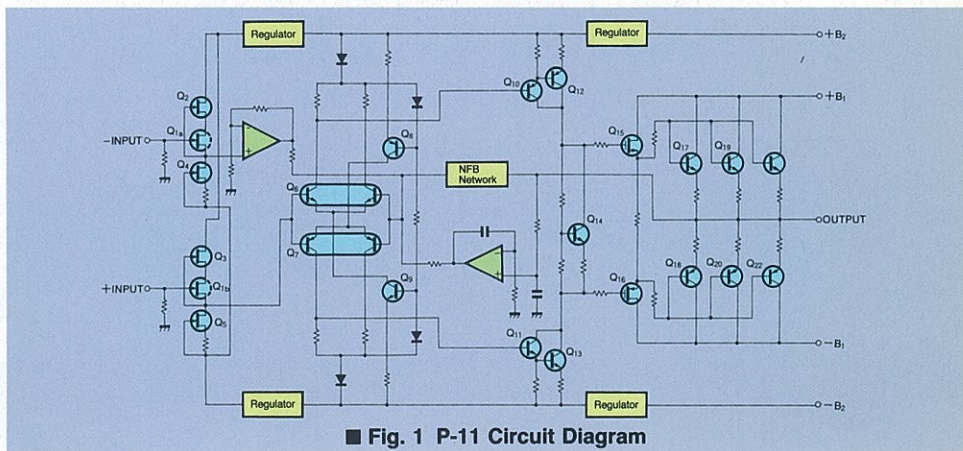

- 1 Thermal sensor transistor
- 2 Class A drive transistor
- 3 N-channel drive power MOS-FET
- 4 NPN output transistors in triple-parallel configuration
- 5 Positive power supply circuit ripple filter
- 6 NPN 1-chip dual transistor
- 7 PNP 1-chip dual transistor
- 8 1-chip dual FET
- 9 Negative power supply circuit ripple filter
- 10 Class A drive transistor
- 11 P-channel drive power MOS-FET
- 12 PNP output transistors in triple-parallel configuration

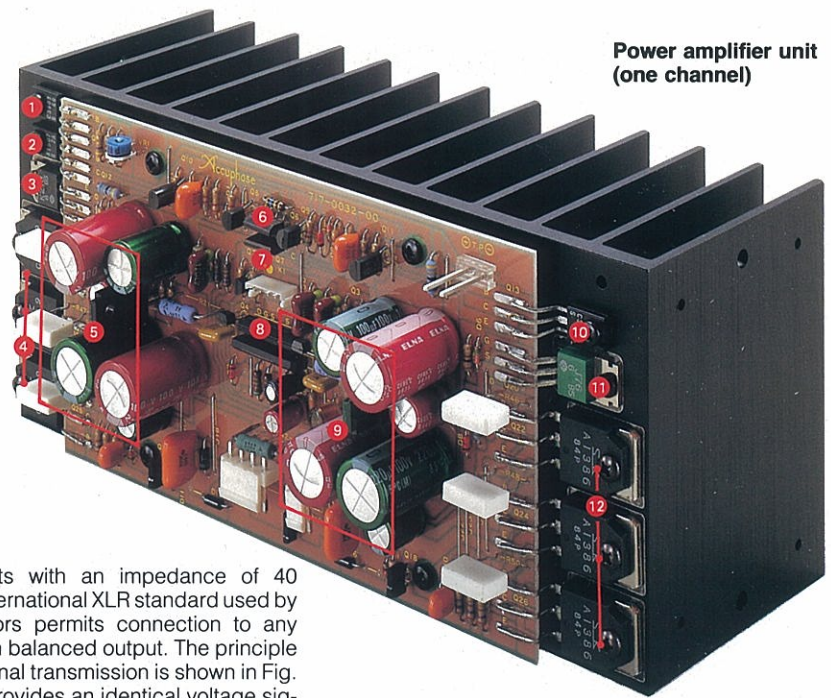

Power amplifier unit (one channel)

P-11 uses separate windings of the power transformer to power the output stage and the driver stages. In the input and predriver stages, the power supply rectifier and regulator circuitry including the filtering capacitors is further divided into separate entities for the left and right channel. This approach keeps interaction between the various stages and between the two channels to an absolute minimum. Phase differences in the left-and right-channel signals are faithfully preserved, resulting in strikingly natural stereo imaging and impressive depth of the sound stage.

## 5 Direct-coupled amplifier with DC servo configuration

As can be seen from Fig. 1, the signal from the input jacks is supplied directly to the INPUT point, without any coupling capacitors in the signal path. This design ensures optimum sound purity. However, if the preamplifier has a large amount of DC drift, a conventional DC connection may lead to the DC voltage being amplified and fed to the speakers, which, of course, can prove fatal. To reliably prevent this possibility, Accuphase has developed the DC servo principle. This circuit effectively blocks DC current. It contributes also to thermal stability and prevents internal DC drift within the amplifier.

## 6 Balanced inputs shut out any external noise

In addition to the regular 20-kilohm RCA-type phono jack connectors, the P-11 also provides

balanced inputs with an impedance of 40 kilohms. The international XLR standard used by these connectors permits connection to any component with balanced output. The principle of balanced signal transmission is shown in Fig. 2. The output provides an identical voltage signal on two lines, one with normal and one with exactly opposite phase. At the input of the next component, these two signals are fed to a positive and negative amplifier and combined by a mixing circuit. As any noise induced during the transmission process has the same phase in both lines, it is canceled out, leaving only the pure and undiluted signal. Especially with long cable runs between components, the advantages of balanced signal transmission are remarkable, ensuring highly superior signal characteristics.

The balanced input circuit of the P-11 is shown in Fig. 3. The positive and negative signals are supplied directly to the differential input circuit, which is ideal for optimum signal purity. This configuration requires separate input level attenuators for the positive and negative input. In the P-11, high-precision ganged attenuators with 1-dB steps are used, which ensures that there are no adverse influences on signal quality or frequency response.

## 7 Two sets of speaker terminals permit biwiring connection

The P-11 provides connectors for two pairs of loudspeakers. The outputs are controlled by relays with extra-high current capability and can be switched to operate either separately or together. Biwiring (connecting the low range drivers and mid/high range drivers of a speaker with separate cables) is therefore also possible.

## 8 Overload indicators show maximum output

As the P-11 has a large power supply and output circuits with high current capability, the audible effects of clipping may not be immediately apparent. However, it is always best to use an amplifier within its rated output power limits. The P-11 therefore provides overload indicators which light up when the maximum power is about to be exceeded.

## 9 Sophisticated design

The front panel retains the traditional Accuphase champagne gold finish, while a thick glass display section in the center lends a striking appearance to the amplifier. The modern visual appeal is further enhanced by the end blocks made of solid metal.

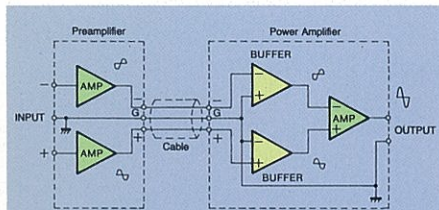

Fig. 2 Principle of balanced output/input configuration

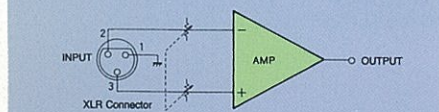
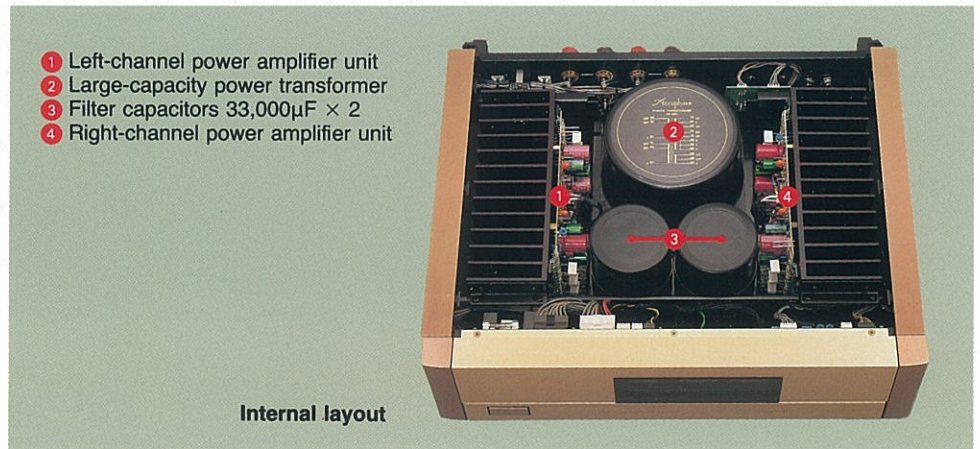

Fig. 3 Balanced Input Circuit



Internal layout

- 1 Left-channel power amplifier unit
- 2 Large-capacity power transformer
- 3 Filter capacitors 33,000 $\mu$ F  $\times$  2
- 4 Right-channel power amplifier unit



# C-11 High-grade, full-function preamplifier for a variety of program sources including analog records. Supplied remote commander.

The range of program sources available for home enjoyment is truly impressive: CDs, analog records, AM and FM broadcasts, tape decks, high-fidelity TVs and VTRs, video discs, direct broadcasting satellites, etc. The preamplifier has the task to select desired source and provide a means to adjust the listening volume, and – if required – the tonal balance of the source. A good preamplifier should also provide recording outputs for tape recorders and facilities for easy tape dubbing. The preamplifier therefore is an important component which is crucial to the entire system and which should function unobtrusively and intuitively.

The preamplifier also has to provide considerable total gain, reaching as high as 80dB (from the MC phono input to the output) which corresponds to a factor of 10,000. Even minor interference between stages is bound to show up in the sound. Quality and signal purity are therefore vital aspects of preamplifier design.

The preamplifier C-11 of the new Accuphase series was developed with all of Accuphase's extensive know-how, using only the finest selected parts. It provides balanced input and output connectors for superior signal transmission characteristics. The equalizer amplifier can handle any type of phono cartridge, and tone controls and tape recorder facilities are also top-notch. While offering a full array of convenient functions, the external appearance of the preamplifier remains uncluttered and visually striking, thanks to the traditional Accuphase subpanel design. A supplied remote commander permits selection of program sources and adjustment of listening volume from the comfort of your listening position.

Because the C-11 is built with high-quality parts to ensure optimum sound, it has quite a substantial weight. However, the slender appearance of its appealing design belies this fact. Together with the matching power amplifier P-11, this pair of components enhances any living room visually as well as aurally.

## 1 Line amplifier with balanced input and output circuits

The line or high-level amplifier is the section of the preamplifier which handles all signals after the phono stage. In the C-11, this section employs a cascade differential input and a class A push-pull output design, resulting in excellent performance characteristics throughout. Residual noise has been reduced to an absolute minimum, for optimum reproduction of high-quality digital program sources.

Another important feature of this line amplifier is the balanced XLR connectors which are provided besides the conventional input and output facilities. The principle of balanced signal transmission is explained in Fig. 2 of the power amplifier section. The design of the C-11 lets you create an entire system using totally balanced connections for unsurpassed sonic purity.

## 2 High-quality MC/MM phono stage brings out the subtle details in analog records

Although digital program sources are becoming ever more popular, the analog record collection is a treasure a true music lover will not easily abandon. The C-11 therefore is designed to provide high-quality reproduction of analog records as well.

Fig. 4 shows the circuit configuration of the phono stage. Separate input circuits are provided to handle both moving-coil (MC) or moving-magnet (MM) cartridges. As the output voltage and output impedance of MM cartridges are high (with impedance reaching 10 kilohms at high frequencies), the input of the MM stage

uses FETs in a parallel configuration ( $Q_1, Q_2, Q_8, Q_9$ ) to ensure high input impedance. The MC section, on the other hand, must ensure optimum S/N ratio, as the signal voltages are very low. Specially selected devices with very low inherent noise ( $Q_5, Q_{10}$ ) are therefore used in the input circuit of this section. The relays 1 and 2 serve to switch between the two input routes. At the same time, the gain is also switched to match the MM or MC output voltage. The audible result of these design aspects is impeccable reproduction of analog records.

## 3 Straight and short signal paths with logic relay control

Long signal paths for input switching and tape monitoring can degrade high-frequency response and impair imaging. In the C-11, all switching is performed by relays which are arranged to permit the shortest possible signal paths. Advanced logic circuits are used to control the relays and to assure accurate and precise operation.

The relays have twin crossbar contacts designed for minimum contact resistance and outstanding long-term reliability.

## 4 Remote commander for program source switching and volume control

With equipment such as CD players and video recorders, remote control is now almost taken for granted. The C-11 provides similar convenience, but with special regard to sound quality, because for Accuphase it would not do to sacrifice sonic purity for convenience. As the inputs

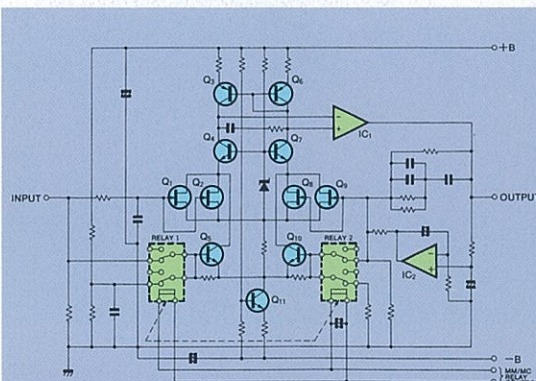

■ Fig. 4 C-11 MM/MC Equalizer Amp.

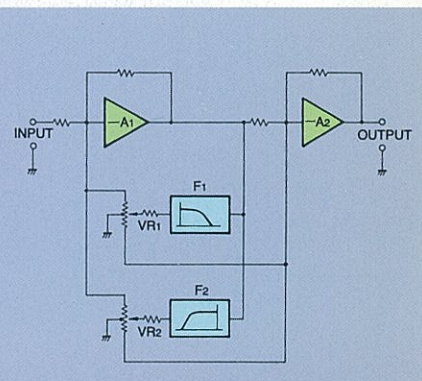

■ Fig. 5 Tone control circuit principle (summing type active filter)

- 1 Output control/muting relays
- 2 Balanced output amplifier
- 3 Input selector display memory/remote control microprocessor (digital circuits in shield enclosure)
- 4 High-level amplifiers
- 5 Recording selector relays
- 6 Input selector relays
- 7 Low-level amplifiers (phono stage with MM-MC switching)
- 8 Regulated power supply

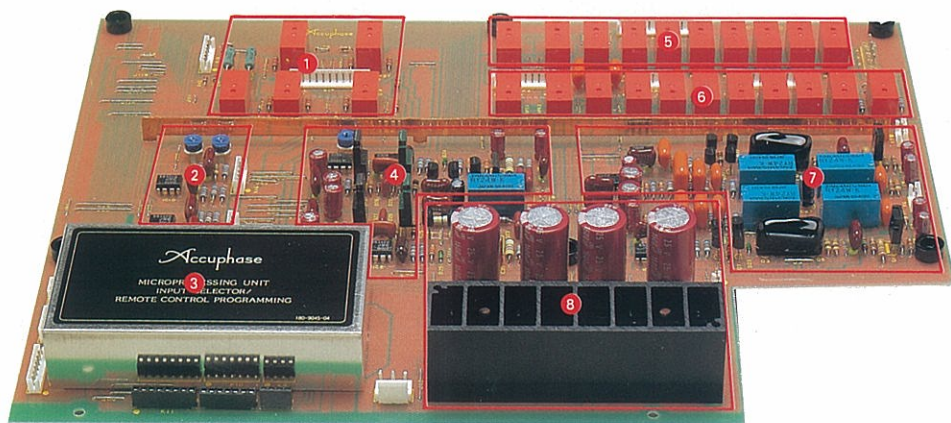

Control units

of the preamplifier are switched using electronically controlled relays, operation of the logic circuits via the remote commander has no influence at all on sound quality. The volume adjustment is performed by a motor-driven manual potentiometer, as this ensures minimum degradation of signal quality.

## 5 Versatile input and output configuration

The C-11 can easily accommodate a variety of program sources and it can also be used, for example, to switch and compare different audio components.

Inputs are provided for two tape recorders, one analog record player, two CD players, one tuner, and four additional line-level components, resulting in a total of ten inputs. Three sets of outputs and one headphone jack ensure versatility on the output side as well. The two balanced inputs (one for CD and one additional line input), and the balanced output use XLR type connectors. Input sources are shown on as character readouts on a LED display with a 5 x 7 dot matrix. The output selector is an additional convenience feature which lets you switch between several power amplifiers.

## 6 Summing tone controls designed for optimum sound quality

In a high-quality component, a means for fine-tuning the sonic energy balance of program sources is sometimes highly desirable, but it, of course, would not do if such a circuit detracted from signal quality as such. The C-11 excels in

this regard also, with a set of newly developed tone controls using the summing filter principle. Consisting entirely of circuit components selected for their sonic performance, the tone controls introduce no deterioration whatsoever. Although not strictly necessary, an On/Off switch also lets you remove the controls entirely from the signal path when not desired. The circuit principle of the tone controls is shown in Fig. 5. The line signal passes straight through, and  $F_1$  and  $F_2$  serve to create desired characteristics which are added to or subtracted from the signal. This principle ensures optimum sound quality.

## 7 Loudness compensator restores natural frequency balance at low listening levels

When volume levels decrease, the human ear becomes less sensitive especially to low frequencies. The loudness compensator switch on the C-11 lets you counterbalance this tendency, by introducing a carefully controlled boost depending on the setting of the volume control.

## 8 Separate recording output selector and copy switch

To make recording from various program sources easy, the C-11 provides a versatile and logical switching arrangement including a recording output selector which is independent of the program source selector. This lets you, for example, record an FM broadcast while listening to a CD. The copy switch permits dubbing between two connected tape recorders.

## 9 Simple and refined low-profile design

The front panel retains the traditional Accuphase champagne gold finish, while the blue metal end blocks further enhance the sophisticated appearance of the unit. Width is the same as the power amplifier P-11, but height has been kept low for a very appealing low-profile look.

Remote commander supplied with C-11



- 1 Relay drive IC
- 2 Volume control motor drive IC
- 3 Regulated power supply IC
- 4 4-Bit microprocessor for 5 x 7 dot LED display control and remote control signal demodulation
- 5 Non-volatile RAM for storage of condition before power OFF

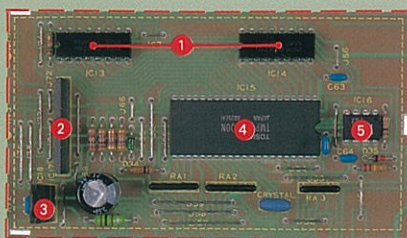

- 1 Power transformer
- 2 Main power supply circuits
- 3 Control units (details see above)
- 4 Motor-driven/manual volume control

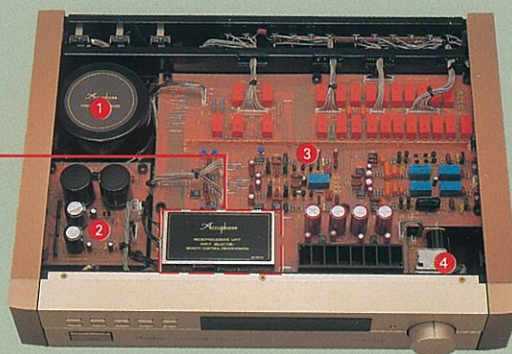

Internal layout

# GUARANTY SPECIFICATIONS

## Performance Guaranty:

All Accuphase product specifications are guaranteed as stated.

### Stereo Power Amplifier P-11

(Guaranty specifications are measured according to EIA standard RS-490.)

- **Continuous Average Power Output (20 – 20,000Hz)**  
Stereo operation (both channels driven)  
170 watts per channel into 4 ohms  
120 watts per channel into 8 ohms  
60 watts per channel into 16 ohms  
Monophonic operation (bridged connection)  
340 watts into 8 ohms  
240 watts into 16 ohms
- **Total Harmonic Distortion**  
Stereo operation (both channels driven)  
0.02%, with 4 ohms load  
0.01%, with 8 to 16 ohms load  
Monophonic operation (bridged connection)  
0.02%, with 8 to 16 ohms load
- **Intermodulation Distortion**  
0.003%
- **Frequency Response**  
20 – 20,000Hz +0, –0.2dB  
(for rated output, level controls at maximum)  
0.5 – 160,000Hz +0, –3dB  
(for 1 watt output, level controls at maximum to –6dB)
- **Gain**  
28.0dB (in stereo and monophonic operation)
- **Output Load Impedance**  
4 to 16 ohms in stereo operation  
8 to 16 ohms in monophonic operation (bridged connection)
- **Damping Factor**  
200 in stereo operation  
100 in monophonic operation (bridged connection)
- **Input Sensitivity (with 8-ohm load)**  
Stereo operation  
1.23V for rated output  
0.12V for 1 watt output  
Monophonic operation (bridged connection)  
2.08V for rated output  
0.12V for 1 watt output
- **Input Impedance**  
Balanced: 40 kilohms  
Unbalanced: 20 kilohms
- **Signal-to-Noise Ratio (A-weighted)**  
115dB with input shorted, at rated output  
93dB with 1-kilohm input termination, at 1 W output
- **Stereo Headphone Output**  
Suitable load impedance: 4 – 100 ohms
- **Semiconductor Complement**  
41 transistors, 14 FETs, 4 ICs, 60 diodes

- **Power Requirements**  
100V, 117V, 220V, 240V 50/60 Hz AC
- **Power Consumption**  
45 watts idle  
300 watts in accordance with IEC-65
- **Dimensions**  
Width 445mm (17-1/2 inches), Height (including feet)  
131mm (5-5/32 inches), Depth 388mm (15-1/4 inches)
- **Weight**  
18.1kg (39.9 lbs) – net  
22.7kg (50.1 lbs) – in shipping carton

### Stereo Preamplifier C-11

(Guaranty specifications are measured according to EIA standard RS-490. AD denotes Analog Disc input.)

- **Frequency Response**  
BALANCED INPUT (CD, LINE)  
1.0 – 400,000Hz +0, –3.0dB  
20 – 20,000Hz +0, –0.2dB  
UNBALANCED INPUT (CD, LINE, TUNER, TAPE PLAY)  
1.0 – 500,000Hz +0, –3.0dB  
20 – 20,000Hz +0, –0.2dB  
AD INPUT  
20 – 20,000Hz ±0.5dB
- **Total Harmonic Distortion**  
0.005% (for all inputs)
- **Input Sensitivity, Input Impedance**

Input	Sensitivity		Input impedance
	For rated output	For 0.5V output	
BALANCED	126mV	31.5mV	40kΩ
UNBALANCED	126mV	31.5mV	20kΩ
AD: MM	4.0mV	1.0mV	47kΩ
AD: MC	0.13mV	0.032mV	100Ω

- **Rated Output Level and Impedance**  
BALANCED OUTPUT: 2.0V, 50Ω (25Ω/25Ω)/XLR connector  
UNBALANCED OUTPUT: 2.0V, 1Ω/RCA-type phono jack  
TAPE REC: 126mV, 200Ω/RCA-type phono jack/AD source
- **Headphone Output**  
Suitable load impedance: 4 – 100Ω
- **Signal-to-Noise Ratio**

Input terminal	Rated Input A-weighted	EIA
BALANCED	97dB	91dB
UNBALANCED	110dB	91dB
AD: MM	90dB	84dB
AD: MC	74dB	83dB

- **Maximum Output Level (THD 0.005%, 20 – 20,000Hz)**  
BALANCED OUTPUT: 8.0V (XLR connector)  
UNBALANCED OUTPUT: 8.0V (RCA-type phono jack)  
TAPE REC: 8.5V (AD source)
- **Maximum AD Input Level (1kHz, THD 0.005%)**  
MM INPUT: 270mV  
MC INPUT: 8.5mV
- **Minimum Load Impedance**  
BALANCED OUTPUT: 600 ohms  
UNBALANCED OUTPUT: 1 kilohm  
TAPE REC: 10 kilohms
- **Tone Controls**  
Turnover frequency and adjustment range  
BASS: 300Hz ±10dB (50Hz)  
TREBLE: 3kHz ±10dB (20kHz)
- **Gain**  
BALANCED INPUT → BALANCED OUTPUT :24dB  
BALANCED INPUT → UNBALANCED OUTPUT :24dB  
BALANCED INPUT → REC OUTPUT :0dB  
UNBALANCED INPUT → BALANCED OUTPUT :24dB  
UNBALANCED INPUT → UNBALANCED OUTPUT :24dB  
UNBALANCED INPUT → REC OUTPUT :0dB  
AD (MM) INPUT → BALANCED OUTPUT :54dB  
AD (MM) INPUT → UNBALANCED OUTPUT :54dB  
AD (MM) INPUT → REC OUTPUT :30dB  
AD (MC) INPUT → BALANCED OUTPUT :84dB  
AD (MC) INPUT → UNBALANCED OUTPUT :84dB  
AD (MC) INPUT → REC OUTPUT :60dB
- **Loudness Compensator Characteristics**  
+6dB (100Hz) at volume setting –30dB
- **Subsonic Filter Characteristics**  
Cutoff frequency 17Hz, –12dB/oct.
- **Attenuator Characteristics**  
–20dB
- **Semiconductor Complement**  
37 transistors, 16 FETs, 33 ICs, 59 diodes
- **Power Requirements**  
100V, 117V, 220V, 240V 50/60Hz AC
- **Power Consumption**  
28 watts
- **Dimensions**  
Width 445mm (17-1/2 inches), Height (including feet)  
95mm (3-3/4 inches), Depth 325mm (12-13/16 inches)
- **Weight**  
9.3kg (20.5lbs) – net  
13.8kg (30.4lbs) – in shipping carton
- **Supplied Remote Commander RC-3**  
Remote control principle: infrared pulse  
Power supply: 3V DC (IEC R6 batteries × 2)  
Dimensions: Width 64mm (3-1/2 inches), Height 149mm (5-7/8 inches), Depth 18mm (11/16 inches)  
Weight: 140g (0.3lbs) (including batteries)

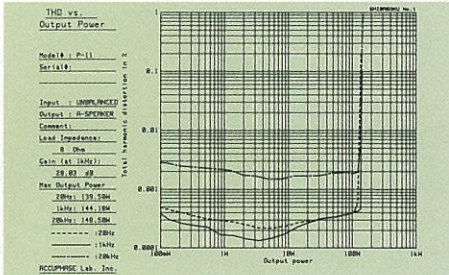

● P-11 Power output vs. THD (8-ohm load, stereo operation)

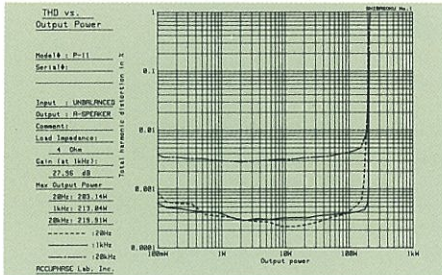

● P-11 Power output vs. THD (4-ohm load, stereo operation)

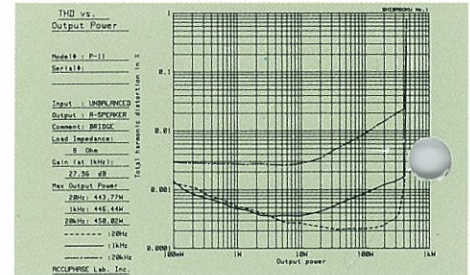

● P-11 Power output vs. THD (8-ohm load, mono operation)

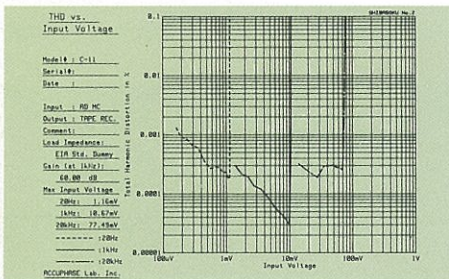

● C-11 Input voltage vs. THD (input: MC, output: tape output)

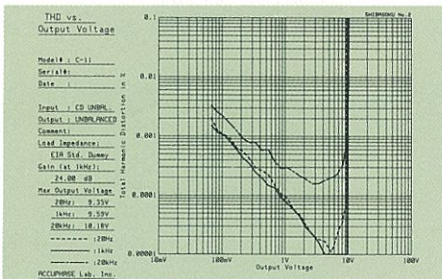

● C-11 Input voltage vs. THD (input: CD unbalanced, output: unbalanced)

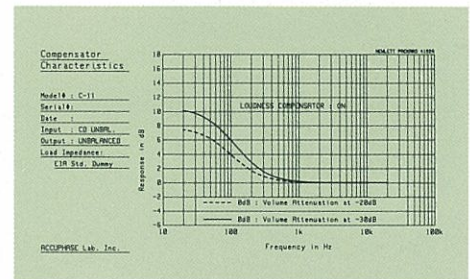

● C-11 Compensator characteristics

