

# Accuphase F-5

ELECTRONIC FREQUENCY DIVIDING NETWORK

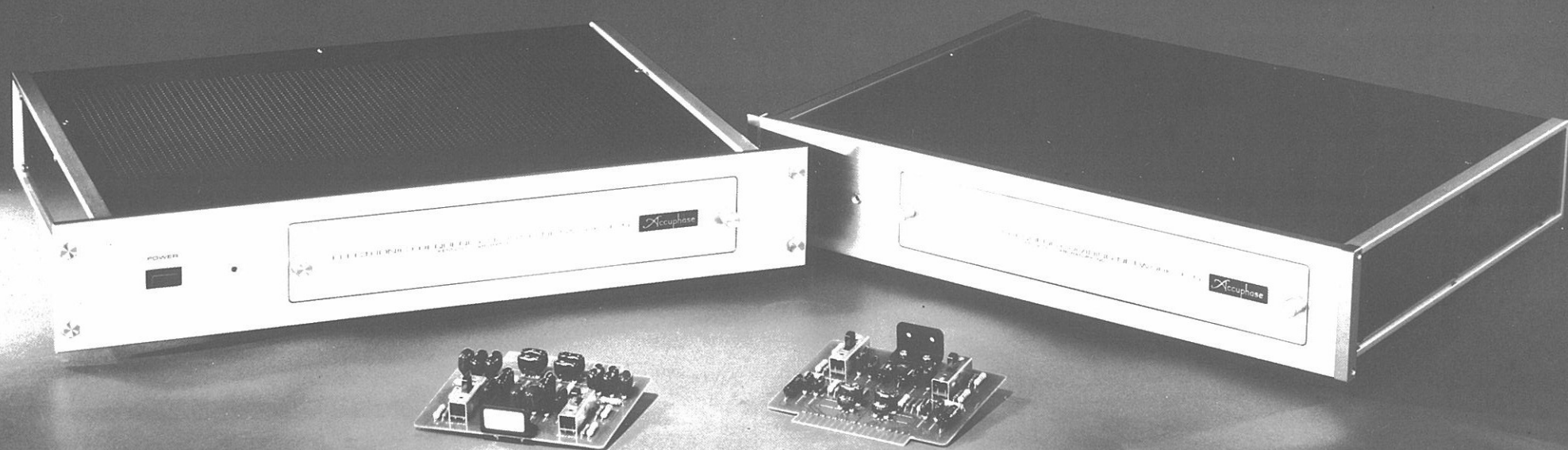

# Accuphase F-5

The Accuphase F-5 is a high quality Electronic Frequency Dividing Network which accurately divides the audio spectrum of a program source prior to amplification and permits multi-channel amplification to drive directly multi-way speaker systems. Such a system has many advantages besides minimal distortion and maximum power transfer, and is especially effective when used to drive irregular impedance horn speakers.

An Electronic Frequency Dividing Network thus functions as the "heart" of a multi-channel amplification system. It is not an exaggeration to say that a greater part of such a system's worth in producing good sound will depend on the quality of the Frequency Dividing Network that is used.

The Accuphase F-5 Electronic Frequency Dividing Network was designed and produced specifically for this one function, to do it best, and most effectively. It is ideal for serving as the "heart" of a bi-amplification or tri-amplification application. If desired the program source can be further divided into four or five audio passbands by using two F-5 units.

To seek the utmost performance, the F-5 is designed only to provide the original functions of a frequency dividing network.

A wide choice of crossover frequency points is available. These are selectable by plug-in "Crossover Boards" contained on separate printed circuits. This minimizes both left and right channel interference, as well as interference between audio passbands. The Operational Amplifier of the active element utilizes a high gain IC with superior high frequency and S/N characteristics. All elements were carefully selected to eliminate any possible coloration or deterioration of sound quality.

## 1 MINIMAL INTER-CHANNEL INTERFERENCE

Even the slightest impurity of signal will be clearly reproduced in a high quality multi-channel amplification system. This makes it imperative to keep interchannel interference, both the left and right channel crosstalk, as well as that between the low medium and high passbands to an absolute minimum. Special importance was attached to this in terms of circuit design, layout and wiring for the F-5, with most gratifying results. For instance, crosstalk between left and right channels for frequencies below 1000 Hz is about -100 dB, and it is around -90 dB for frequencies above 10 kHz, which compares favorably with the excellent noise level ratios.

## 2 HIGH GAIN AMPLIFIER ASSURES IDEAL ATTENUATION CHARACTERISTICS

The slopes of an active filter attenuate to a certain level, after which they reverse its characteristic. This happens when the gain of the active element has reached its limit and has lost its

effectiveness. To keep this limiting point as low as possible, an active element with maximum original gain should be utilized. This is achieved in the F-5 with A-class DC Operational Amplifier IC, with the resulting high gain of 100 dB, as well as high S/N and superior transient characteristics.

## 3 CROSSOVER FREQUENCY SELECTABLE WITH PLUG-IN SYSTEM

To assure good channel isolation, the crossover frequency points are changed by plug-in Crossover Boards, on which are mounted the required CR elements. Expensive silvered-mica capacitors are used unsparingly wherever sound quality may be affected. For this reason the cost of the Crossover Boards differ according to the crossover frequency point, and these plug-in Boards are sold separately.

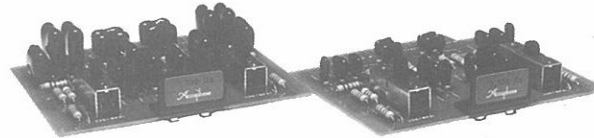

↑ Plug-in crossover board

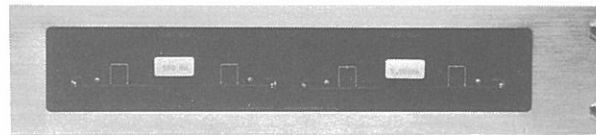

↑ Internal view of the Sub-Panel

## 4 WIDE CHOICE OF 16 STANDARD CROSSOVER FREQUENCIES

The following Crossover Boards are available which allow choice of 16 crossover frequency points, and provide audio passbands for almost any combination of two to five way applications: 100Hz, 180Hz, 250Hz, 350Hz, 500Hz, 650Hz, 800Hz, 1,200Hz, 1,800Hz, 2,500Hz, 3,500Hz, 5,000Hz, 7,000Hz, 8,000Hz, 10,000Hz, 12,500Hz.

## 5 SELECTABLE 12dB/Oct or 18dB/Oct CROSSOVER ATTENUATION

Selection of cut-off attenuation at the crossover frequency between the most common 12dB per octave, or the 18dB per octave, which is suitable for certain horn type speakers, can be made easily with the Selector Switch that is positioned on the Crossover Board.

## 6 UTILIZATION FOR OTHER THAN 3-WAY APPLICATION

The F-5 can also be used readily for 2-way application. Merely use the Bi-Amplification Board that is sold separately, and plug it into the mid-high frequency crossover socket. Two F-5 units can be used simultaneously to form a 4 or 5 way amplification.

## 7 BUILT-IN MID-HIGH LEVEL CONTROL

The level control of the Power Amplifier should be used normally for controlling the level of that respective channel. Therefore, a level control each for mid and high has been made available in the F-5 for level control functions in case the amplifier that is used has no such provisions.

## 8 CHOICE OF TWO DESIGNS

This Electronic Frequency Dividing Network is available in two designs, type F-5A and F-5B. The F-5A matches the M-60 and P-20 and is suitable for rack mounting. The F-5B is a side plate type which matches the P-300 and P-250.

Type A : Mountable on 19" standard rack

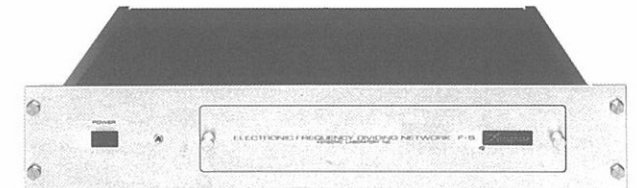

Type B : Front panel designed to match P-300/P-250/C-200/T-100

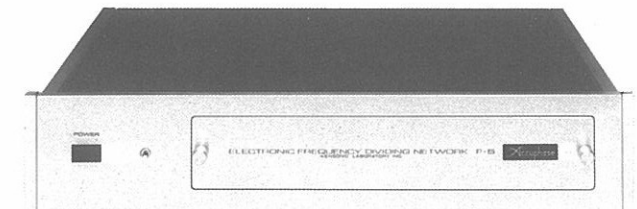

## GUARANTY SPECIFICATIONS

Performance Guaranty: Products of Accuphase guarantee specifications stated.

GAIN: 0 dB  
 MAXIMUM OUTPUT: 6.5 Volts  
 TOTAL HARMONIC DISTORTION: 0.1% (from 20 Hz to 20,000 Hz at 6.5 V output)  
 FREQUENCY RESPONSE: +0, -0.2 dB, 20 Hz to 20,000 Hz equivalent bandwidth  
 CROSSOVER FREQUENCY: Selectable by Plug-in Modules  
 CROSSOVER POINT: -3.0 dB,  $\pm 5\%$   
 FILTER SLOPE: 12 dB/oct. 18 dB/oct. changeable  
 INPUT IMPEDANCE: 100 kohms  
 HUM AND NOISE: 100 dB at 2.0 V output, 20 Hz to 20,000 Hz  
 OUTPUT IMPEDANCE: L.F. 600 ohms  
 M.F. 600-2,500 ohms (depending on setting of level control)  
 H.F. 600-2,500 ohms (depending on setting of level control)

OUTPUT LOAD IMPEDANCE: 10 kohms minimum  
 CONTROLS: MID. output level, HIGH output level, ON/OFF switch

POWER REQUIREMENT: Voltage Selector for 100V, 117 V, 220 V, 240 V 50/60 Hz operation

Consumption: 14 watts  
 SEMICONDUCTOR COMPLEMENT: 7 Transistors, 16 IC's, 2 FET's, 12 Diodes

DIMENSIONS: (Type A) 482 mm (19 inches) wide, 82 mm (3-1/4 inches) high, 345 mm (13-9/16 inches) deep  
 \*mountable on 19" standard rack, rack mount pitch; 50 mm (2") rack inside horizontal measurement; 430 mm (16-15/16")  
 (Type B) 445 mm (17-1/2 inches) wide, 82 mm (3-1/4 inches) high, 349 mm (13-3/4 inches) deep

WEIGHT: (Type A, B) 7.6 kgs (16.7 lbs) net, 11.6 kgs (25.5 lbs) in shipping carton

## MODEL NO. OF THE CROSSOVER BOARDS

Crossover Frequency	Model No.
100 Hz	CB-100
180 Hz	CB-180
250 Hz	CB-250
350 Hz	CB-350
500 Hz	CB-500
650 Hz	CB-650
800 Hz	CB-800
1,200 Hz	CB-1200
1,800 Hz	CB-1800
2,500 Hz	CB-2500
3,500 Hz	CB-3500
5,000 Hz	CB-5000
7,000 Hz	CB-7000
8,000 Hz	CB-8000
10,000 Hz	CB-10000
12,500 Hz	CB-12500
2-WAY Board	CB-2WAY

## TOTAL HARMONIC DISTORTION VS OUTPUT VOLTAGE

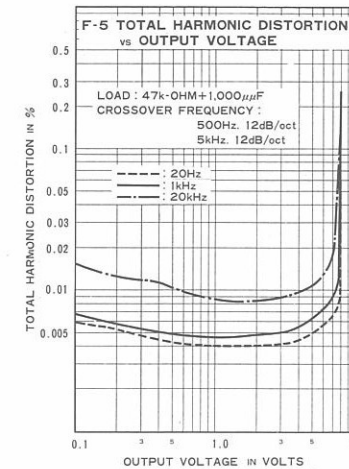

## PERFORMANCE CURVES

### FILTER CHARACTERISTICS

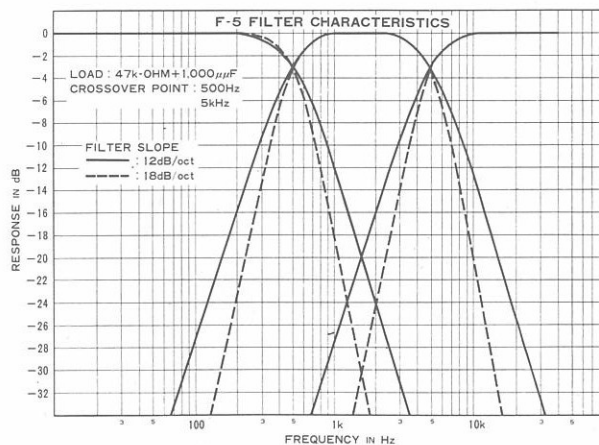

### SEPARATION CHARACTERISTICS

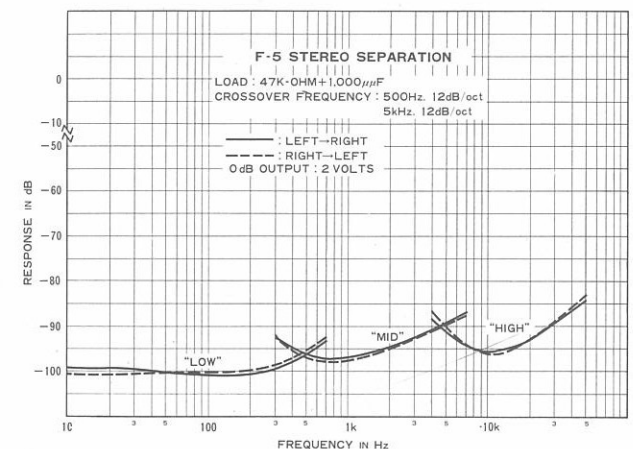



# Accuphase F-5

BLOCK DIAGRAM SHOWS 2-TO 5-WAY APPLICATIONS

## ● 2 Way

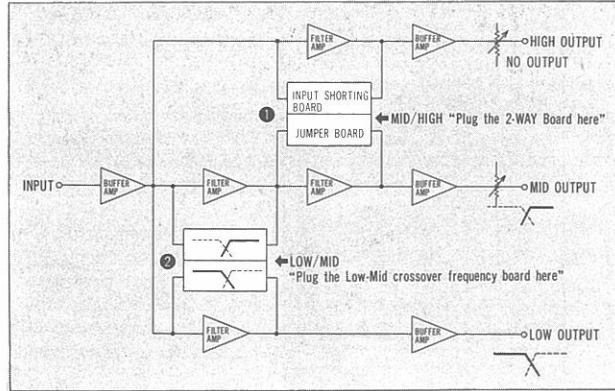

## ● 3 Way

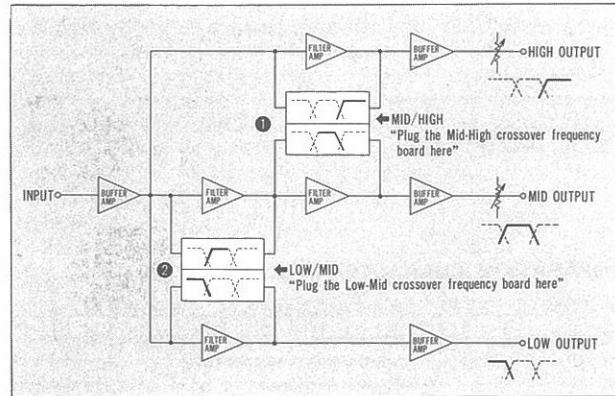

Bi-Amplification, which has one crossover frequency, requires one crossover frequency board and a special 2-WAY board. The crossover board should be plugged into the "LOW/MID" crossover socket. The special 2-WAY board should be plugged into the "MID/HIGH" socket. Tri-Amplification, however, is the most standard method.

## ● 4 Way

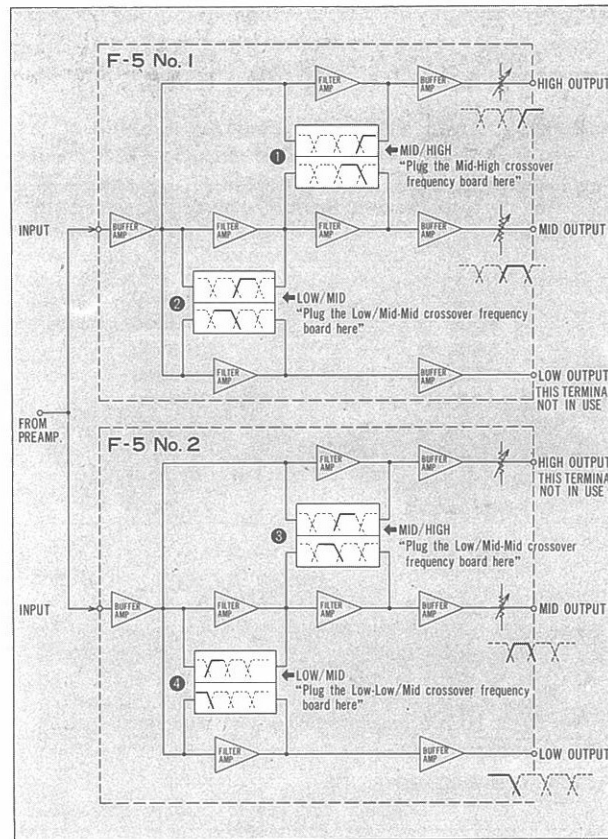

Two F-5 units are required for a Quadri-Amplification installation. Both units should be connected in parallel, and fed simultaneously with the preamplifier output. Two crossover boards of identical frequency should be used for the crossover boards designated ② and ③. This means an additional cost, but sound quality that can be obtained through this amplification is well worth it. The LOW OUTPUT of the F-5 No. 1 and the HIGH OUTPUT of the F-5 No. 2 are not used in this amplification system.

## ● 5 Way

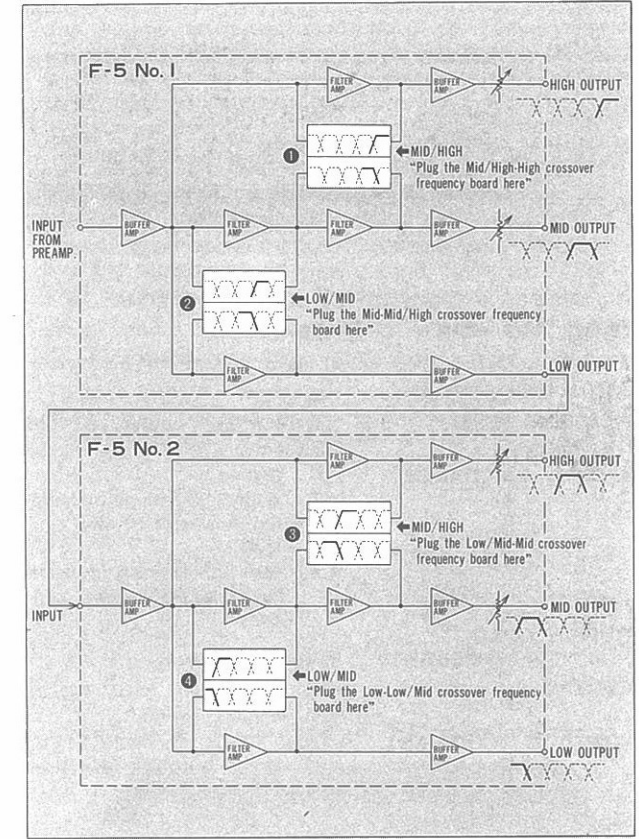

In a 5-WAY Amplification system, two F-5 units are connected in series. To have a better S/N ratio, preamplifier output should be connected to the INPUT of F-5 No. 1, which provides the mid-high and high audio frequency bands respectively. The LOW OUTPUT of F-5 No. 1 is fed into the F-5 No. 2, which then supplies the middle, mid-low and low frequency audio passbands respectively from its HIGH, MID and LOW outputs.