

Accuphase

SUPER AUDIO CD PLAYER

DP-78

- High-grade playback not only of SA-CDs but also of conventional CDs
- Single lens/twin pickup high-speed access mechanism
- Digital processor ready for 2.8224 MHz/1-bit and 192 kHz/24-bit source formats
- MDS++ D/A converter achieves minimal distortion and outstanding S/N ratio
- Transport section outputs and digital inputs
- HS-Link input/output capability via option boards





An SA-CD/CD player of the highest order – Processor section supports high-quality formats such as 2.8224 MHz/1-bit and 192 kHz/24-bit. Further improved MDS++ D/A converter. Transport section features dedicated DSP for digital servo and single lens/twin pickup high-speed access mechanism. Separate construction of transport and processor sections and respective connectors allow independent use. HS-Link input/output boards available as option.

The Accuphase separate type player combo DP-100 and DC-101 incorporating HS-Link connectivity is recognized both in Japan and overseas as the ultimate setup for SA-CD playback. It is the standard against which all others have to be measured. And now, the superior technological know-how gained through the development of this combo has found another manifestation in the integrated SA-CD/CD player DP-78. Incorporating the latest advances in digital technology, the DP-78 is destined to take its place at the top of its class. By concentrating solely on two-channel sources both in the SA-CD and CD format, the DP-78 lets you fully enjoy the best that orthodox music reproduction has to offer.

Ever since its introduction in 1999, the SA-CD catalog of hybrid discs has been expanding. With its 2.8224 MHz/1-bit format, the SA-CD stores four times as much information as a conventional CD at 44.1 kHz/16-bit. This allows it to realize dramatically superior physical performance as manifested by wider frequency response and dynamic range. The DP-78 is equipped to make full use of this impressive potential. It will let you rediscover the deep joy and satisfaction that a truly outstanding musical experience can offer. But the DP-78 not only handles the SA-CD format with impeccable finesse, it will bring out the best from conventional CD sources as well. Be prepared for a wholly new encounter with your entire musical catalog.

The SA-CD/CD transport section and the processor section of the DP-78 are kept entirely independent of each other, to achieve optimum performance in each regard. The transport features a single lens/twin pickup high-speed access mechanism, combined with a digital servo controlled by its own DSP. This advanced approach assures highly accurate processing of the digital signal and excellent support for high-sampling-frequency sources including 2.8224 MHz/1-bit and 192 kHz/24-bit. The DAC – a key component for determining sound quality – incorporates a further refined version of the acclaimed MDS principle, called MDS++. As a result of this non-holds-barred approach, the DP-78 projects a sound stage of unprecedented realism and sheer musical perfection.

SA-CD/CD Transport Section Features and Functions

- Digital servo with dedicated DSP assures highly accurate signal pickup for SA-CDs and CDs
- Plays also regular CDs with outstanding quality
- Single lens/twin pickup mechanism minimizes access time
- Support for text data display including disc title and artist name information
- Strong, precision-machined chassis with resonance and vibration resistant construction
- SA-CD/CD transport output via optional HS-Link Output Board DO2-HS1 (see connection example below)
- "High Carbon" cast iron insulator feet with superior damping characteristics further enhance sound quality
- Multi-function remote commander RC-100 supplied as standard equipment
- Dedicated coaxial and optical connectors for CD signal output

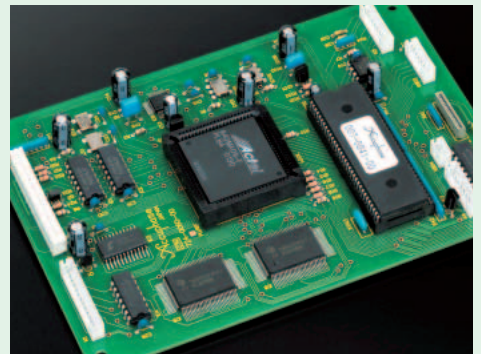

Transport section outputs

► Assembly with master clock generator, DAI encoder/decoder, ultra jitter-free PLL circuit, and other digital signal processing circuitry

Connection example for effective use of SA-CD/CD transport

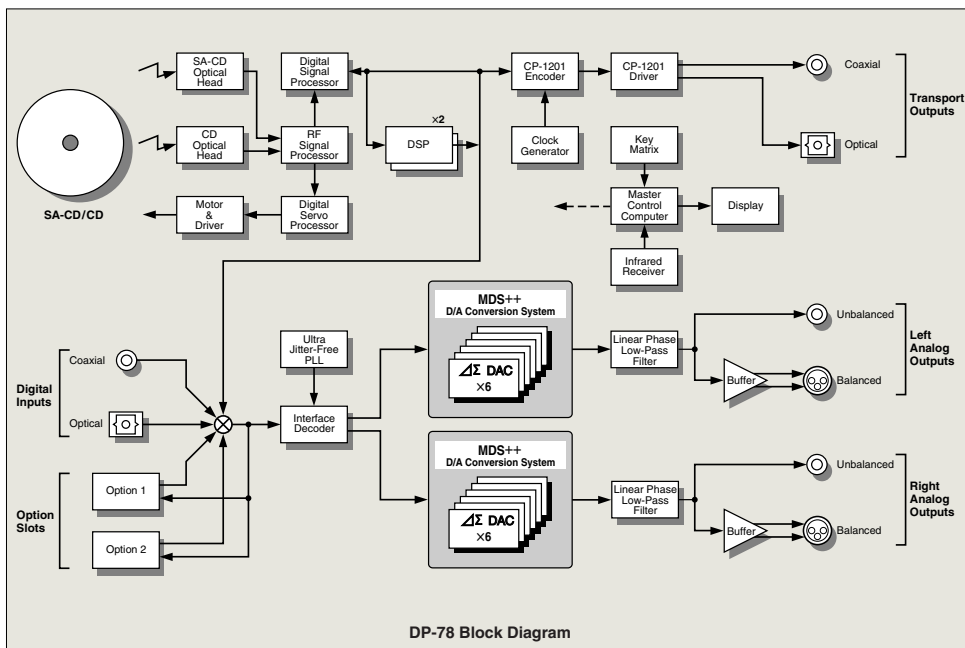
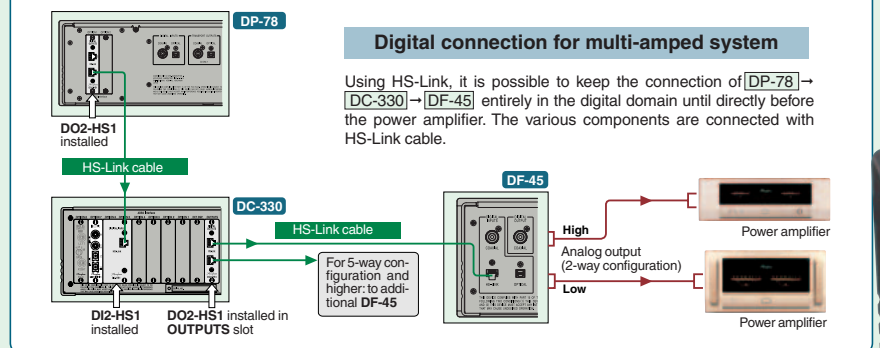

Accuphase Original Digital Interface HS-Link: High Speed Link

HS-Link is an ultra high-quality digital audio interface developed by Accuphase using the latest digital signal transmission technology. It supports send/receive verification for copyright protection. The LVDS (Low Voltage Differential Signaling) principle allows a single dedicated HS-Link cable to transmit signals using advanced digital audio formats such as 2.8224 MHz/1-bit or 192 kHz/24-bit. Because digital audio data are transmitted with utmost fidelity, the sound quality achieved by HS-Link is outstanding.

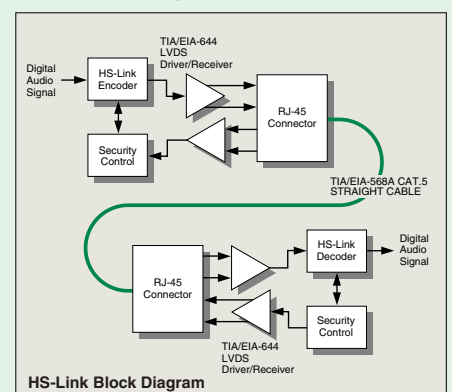

Further Refined MDS++ D/A Converter

The output signal is produced by an MDS++ Type D/A converter which boasts ultimate performance and impeccable sound quality. MDS (Multiple Delta Sigma) is a revolutionary design which employs several delta sigma type converters in a parallel configuration for greatly improved accuracy.

As is evident from the illustration, combining the output signal from individual converters causes mutual cancellation of conversion errors, resulting in a notable improvement in all relevant aspects of conversion performance: accuracy, S/N ratio, dynamic range, linearity, and THD.

The DP-78 uses six Analog Devices AD1955 delta sigma converters in parallel, which affords an overall performance improvement by a factor of $2.4 (\sqrt{6})$.

The MDS++ type converter in the DP-78 (block diagram shown below) features improved operation of the I-V (current-to-voltage) circuit and uses a combination of current adding and voltage adding, to reduce the load on the current adder. This results in better stability and further improved performance. Music emerges from a totally silent background and is reproduced with incredibly accurate spatial imaging.



Delta sigma type D/A converter

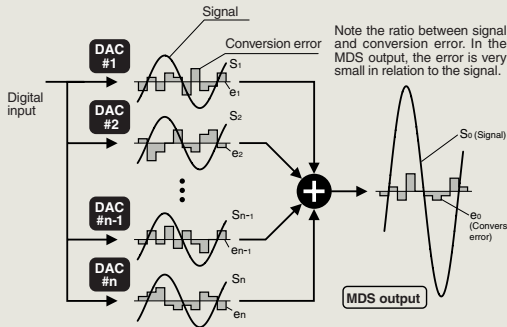

■ MDS type D/A converter principle

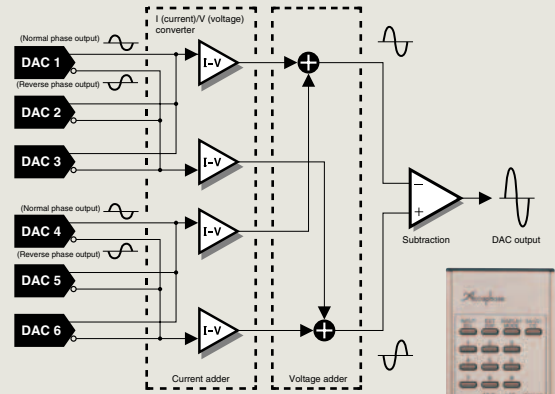
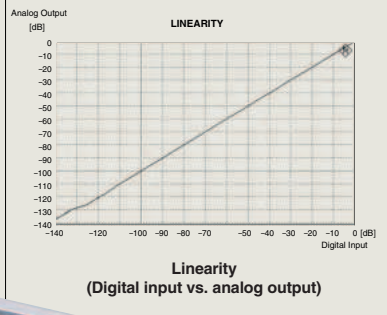

■ Block diagram of MDS++ converter

■ Supplied remote commander RC-100
Functions include input switching, output level adjustment, direct play, repeat, program, shuffle, etc.



Digital Processor Section Features and Functions

The processor section incorporates the MDS++ D/A converter developed by Accuphase, assuring optimum performance and sound quality. The performance of the processor can be accessed also by external components, for digital signal reproduction of the highest standard.

- Digital processor supports new generation formats with high sampling rates such as 2.8224 MHz/1-bit and 192 kHz/24-bit.
- MDS++ type D/A converter achieves stunning performance and sound quality.
- Ultra jitter-free PLL circuit topology totally eliminates adverse influences from jitter and pulse distortion.
- Fully separate processor section with coaxial and optical digital inputs that support sampling frequencies up to 96 kHz and 24-bit resolution. HS-Link input board is available as an option.
- Digital level control with adjustment range of 0 dB to -60 dB.
- Third-order linear phase analog filters ensure excellent phase characteristics.
- Balanced and unbalanced analog outputs.

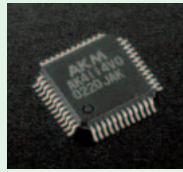

Digital demodulator IC



Digital input connectors



Analog output connectors

Front panel

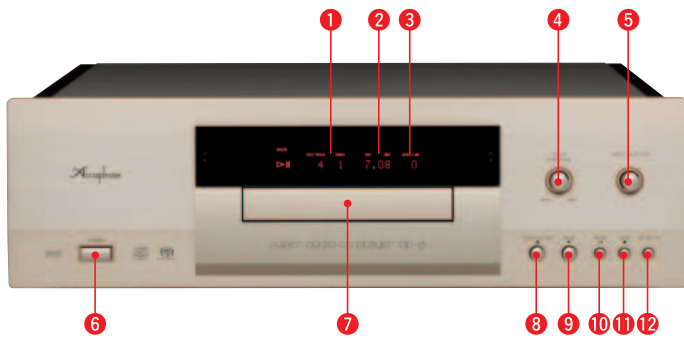

Rear panel

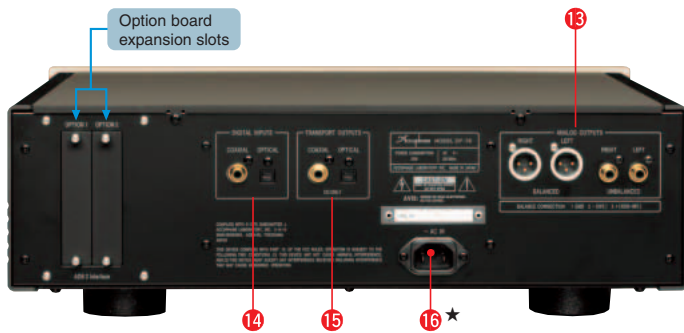

- | | |
|-------------------------------|---------------------------------------------------|
| 1 Track/index indicator | 9 Play button |
| 2 Time indicator | 10 Pause button |
| 3 Output level indicator | 11 Stop button |
| 4 Track search knob | 12 SA-CD/CD selector button |
| 5 Input selector | 13 Analog output connectors (unbalanced/balanced) |
| 6 Power switch | 14 Digital input connectors (coaxial, optical) |
| 7 Disc tray | 15 Transport output connectors (coaxial, optical) |
| 8 Disc tray open/close button | 16 AC inlet★ |

Remarks

- ★ This product is available in versions for 120/230 V AC. Make sure that the voltage shown on the rear panel matches the AC line voltage in your area.
- ★ The shape of the AC inlet and plug of the supplied power cord depends on the voltage rating and destination country.

- Supplied accessories:
- AC power cord
 - Remote commander RC-100
 - Audio cable with plugs (1 m)

Option board type

The DP-78 allows separate use of its SA-CD/CD transport section and digital processor section, for connection to other digital components. Besides the digital input and output provided as standard equipment, there are also two option board slots on the rear panel which accept various kinds of boards.

- ※ For copyright reasons, the SA-CD signal does not appear at any other output except HS-Link and can therefore not be recorded digitally.

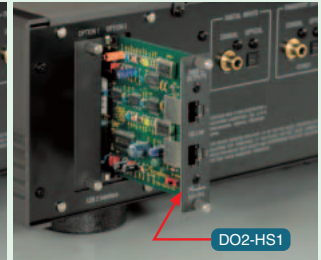
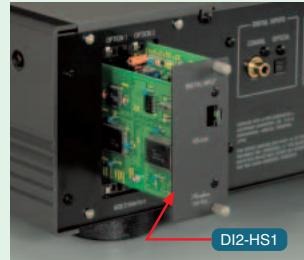

Option board type

Option board type	
Digital Input/Output Board	DIO-OC1
HPC Coaxial (ST) Input/Output Board	DIO-ST1
AES/EBU Input/Output Board	DIO-PRO1
HS-Link Output Board	DO2-HS1
HS-Link Input Board	DI2-HS1

- HS-Link cable HDL-15 (1.5 m)
(The HDL-15 is also available in 3 m, 5 m, 7.5 m, and 10 m lengths.)

Guaranteed Specifications

[Guaranteed specifications measured according to JEITA standard CP-2402]
[Measurement disc: PHILIPS 3122-783-00632]

Transport Section

- **Compatible disc formats** 2-channel Super Audio CD
CD
- **Data read principle** Non-contact optical pickup
- **Laser diode wavelength** SA-CD: 650 nm
CD: 780 nm
- **Transport outputs** Format: JEITA CP-1201 compliant
COAXIAL: 0.5 Vp-p, 75 ohms
OPTICAL: -21 to -15 dBm, wavelength 660 nm

Digital Processor Section

- **Digital inputs** COAXIAL Format: JEITA CP-1201/AES-3 compliant
OPTICAL Format: JEITA CP-1201 compliant
Sampling frequencies
32 kHz, 44.1 kHz, 48 kHz, 88.2 kHz, 96 kHz
(16 to 24-bits, 2-channel PCM)
[Implemented by option board]
176.4 kHz, 192 kHz (24-bits, 2-channel PCM)
2.8224 MHz (1-bit 2-channel DSD)
- **D/A converter** MDS++ type, 24-bits
- **Frequency response** 0.5 - 50,000 Hz +0, -3 dB
- **Total harmonic distortion** 0.0008% (20 to 20,000 Hz)
- **Signal-to-noise ratio** 114 dB
- **Dynamic range** 110 dB (24-bit input, low-pass filter off)
- **Channel separation** 108 dB (20 to 20,000 Hz)
- **Output voltage and impedance** BALANCED: 2.5 V at 50 ohms, balanced XLR type
UNBALANCED: 2.5 V at 50 ohms, RCA phono jack
- **Output level control** 0 to -60 dB, 1-dB steps (digital)

General

- **Power requirements** AC 120 V /230V (voltage as indicated on rear panel)
50/60 Hz
- **Power consumption** 25 W
- **Maximum dimensions** Width 465 mm (18-5/16")
Height 150 mm (5-7/8")
Depth 397 mm (15-5/8")
- **Mass** 18.4 kg (40.6 lbs) net
24.0 kg (53.0 lbs) in shipping carton
- **Supplied Remote Commander RC-100**
Remote control principle: infrared pulse
Power supply: Two IEC R03 (size AAA) batteries
Max. dimensions: 56 mm x 175 mm x 26 mm
Mass: 155 g (including batteries)



ACCUPHASE LABORATORY INC.

J0511Y PRINTED IN JAPAN 850-0149-00 (AD1)

• Specifications and design subject to change without notice for improvements.

<http://www.accuphase.com/>