

# Accuphase

MMB COMPACT DISC PLAYER

## DP-65

●MMB type D/A converter yields 20-bit linearity and minimizes noise ●Servo motors with ground-free balanced drive ●20-bit, 8-times oversampling digital filter ●40 MBit/s optocoupler guarantees thorough separation of digital and analog sections



COMPACT  
disc  
DIGITAL AUDIO



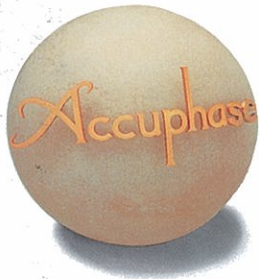

# MMB type D/A converter approaching 1 Complemented by high-quality 20-bit, 8 filter and GIC 3-pole analog Butterworth 40 MBit/s optocoupler assures thorough Massive, solid chassis and tray-lock me

Ever since the birth of the CD, technical progress has been advancing at an amazing rate. Some manufacturers invest considerable efforts in making CD players more affordable, while others worked hard to achieve better sound. Accuphase always was a forerunner in the field of sonic advancement, as demonstrated by the 20-Bit Discrete D/A Converter, the introduction of optical signal transmission, the elimination of digital interference, and many other breakthroughs. As a case in point, the separate-type CD reproduction system consisting of the Transport DP-90 and Processor DC-91 has been widely acknowledged as redefining the art of digital audio. The MMB (Multiple Multi-Bit) D/A converter developed for the DC-91 offers sonic resolution that is nothing short of amazing, thanks to a no-holds-barred design with 16 strictly selected 20-bit converters connected in parallel. With its outstanding linearity and virtual absence of residual noise, this converter type represents the pinnacle of the multi-bit principle.

The DP-65 is an integrated CD player that has inherited many of the technological innovations championed by the DP-90/DC-91 combination. In sound quality, it comes astonishingly close to those stunning performers. One of the guiding principles during the development of the DP-65 was the pursuit of peerless 20-bit performance. Its D/A converter is an MMB type with four strictly selected 20-bit elements connected in parallel, to assure ideal digital-to-analog conversion characteristics. Linearity of analog output versus digital signal input is excellent over the entire dynamic range, from very high to extremely low signal levels. Distortion and noise are virtually absent.

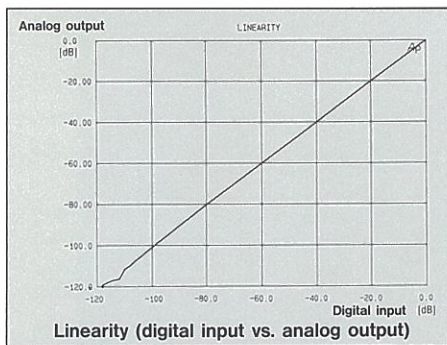

The mechanical side of the DP-65 also has a lot to offer. The laser pickup assembly is designed with an integrated, ultra-compact RF amplifier which makes the output signal much less prone to noise and interference. This contributes to a notably reduced error rate. The motors and actuators for moving parts such as the disc tray, spindle, sled, as well as the focussing and tracking assembly are driven by balanced circuitry where no current flows in the ground line. Current fluctuations therefore cannot enter the sig-

nal path and adversely affect the sound. The locking tray design maintains a firm hold of the tray during playback, to prevent harmful vibrations and resonances. The entire CD mechanism is mounted on a massive metal chassis that offers high rigidity and effectively absorbs vibrations arising inside as well as outside the player. The DP-65 covers all bases, with top quality in every mechanical as well as electronic aspect. The end result is a digital signal of exceptional purity.

The digital and analog sections use an ultra high speed optocoupler link that guarantees thorough electrical isolation. Two separate power transformers for the digital and analog sections provide further separation, to eliminate any possibility of sound quality degradation through RF interference. The digital volume control and the balanced output circuitry help to maintain totally accurate sound reproduction. Behind the simple and elegant front panel of this CD player resides a wealth of highly sophisticated Accuphase technology. Thanks to the DP-65, the world of digital audio has just become even more fascinating and enticing.

## MMB type D/A converter yields 20-bit linearity and minimizes noise

The D/A converter, an essential component for sound quality, is an MMB type originally developed for the DC-91. This converter system has won high praise for its breathtaking performance and impeccable sound quality. The acronym MMB stands for "Multiple Multi-Bit" and refers to a design where a number of strictly selected 20-bit D/A converters are connected in parallel. The parallel drive principle has proven its worth in many electronic applications, such as high-performance phono preamplifiers and high-frequency transistors. When properly designed, it dramatically reduces noise and improves frequency response.

The improvement afforded by the parallel connection is exemplified by the fact that connecting two elements in parallel will yield twice the current but distortion and residual noise will increase only by a factor of 1.4. The improvement in terms of signal versus noise in this case is 3 dB. With several elements in parallel, the improvement can be calculated according to the following equation, where "n" is the number of parallel elements:

$$20 \log (1/\sqrt{n}) \text{ [dB]}$$

Since the DP-65 uses four elements, the improvement is 6 dB.

Rather than simply linking the converter elements in parallel, the MMB circuit drives each converter separately, so that it can develop its full potential. Special attention was devoted to phase response at high frequencies. Parts selection, layout, and wiring patterns were optimized to achieve harmonious performance. In other words, Accuphase applied the parallel connection

principle only after ensuring that each converter would operate perfectly on its own. This is the real reason why MMB sounds so good.

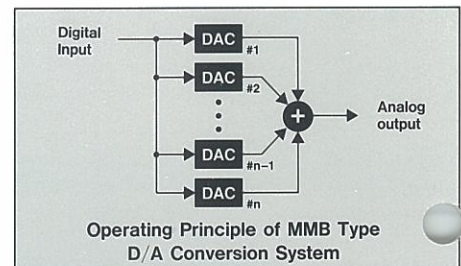

As can be seen from the graph, response of digital input versus analog output is absolutely linear from very high to extremely low levels, down to an amazing -110 dB (actual measurement; the limit of 16-bit CDs is -96 dB). Distortion and noise are also virtually absent, so that the converter attains the theoretical limits of performance. The sonic result is breathtaking realism and almost incredible detail resolution. Even the most delicate nuances of a pianissimo passage suddenly emerge with total clarity and fidelity.

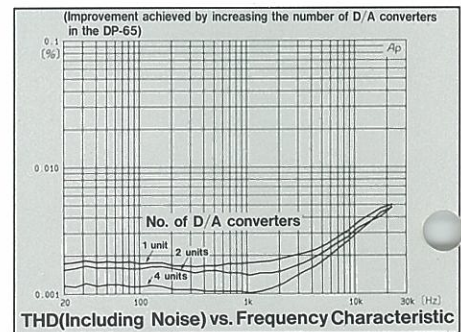

## High-performance 20-bit, 8-times oversampling digital filter

The purpose of a digital filter is to multiply the sampling frequency by an integer, thereby moving any spurious noise components far outside the audible range.

The filter in the DP-65 is manufactured by NPC and employs a linear-phase FIR (Finite Impulse Response) three-stage design in the interpolation stage. This assures perfect linearity, since the filter introduces no group delay, and ripple components in the passband are reduced to an astonishing  $\pm 0.00005$  dB. Attenuation in undesired area is better than -110 dB. The filter thus approaches the theoretical limits of performance. The deemphasis stage features an





# limits of 20-bit performance precision. mes oversampling digital filter. eparation of digital and analog sections. nism prevent resonances.

IIR (Infinite Impulse Response) design to assure precise gain and phase characteristics.

### GIC 3-pole analog filter with hand-selected components

Even a CD player with a high-performance 8-times oversampling digital filter such as the DP-65 still needs an analog filter to recreate the audio waveform and remove the remnants of digital components. However, since these components are located above 332.8 kHz, the DP-65 employs a GIC (Generalized Impedance Converter) 3-pole Butterworth type with a gentle rolloff curve. All components of the discrete filter stage are hand-selected, to assure sonic purity and total musical accuracy.

### Digital level control prevents sound quality deterioration

The ultra-precise digital attenuator operates in the digital filter stage and introduces

no sound quality deterioration whatsoever. In conventional converters, a phenomenon called "round-off error" causes digital noise as attenuation increases. Not so in the DP-65. Since the 20-bit MMB D/A converter has a 4-bit margin, attenuation is possible down to -40 dB.

### Total separation of digital and analog sections

Since a digital signal consists of regular, periodic codes, it can — if allowed to enter the analog signal path — cause noise that is clearly distinct from analog sources. The result is muddy, unclear sound. To prevent this danger, a thorough separation of the digital and analog sections is necessary, in terms of static as well as induced interference. The DP-65 therefore features ultra high performance optoisolators

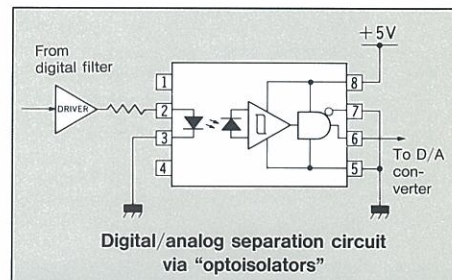

manufactured by Hewlett-Packard. These sophisticated devices have a transmission rate of 40 MBit/second. The optical principle prevents unwanted mutual interaction and reliably shuts out noise interference. Separate power transformers for the analog and digital sections are vital to prevent noise intrusion via the power supply. Of course, the rest of the power supply circuitry must also be kept separate. In the

### Digital assembly

Digital circuitry including OP amp for mechanical actuator drive, servo control IC, digital signal processing ICs, 8-bit microprocessor, and 20-bit 8-times oversampling digital filter.

- 1 Optical digital output connector
- 2 Coaxial digital output connector
- 3 Actuator drive ICs
- 4 Laser pickup power supply
- 5 Servo signal processor (rear side)
- 6 CD decoder DSP chip (rear side)
- 7 8-bit microprocessor for system control
- 8 20-bit 8-times oversampling digital filter

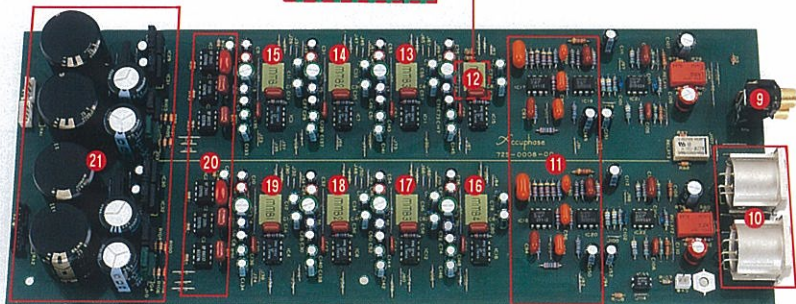
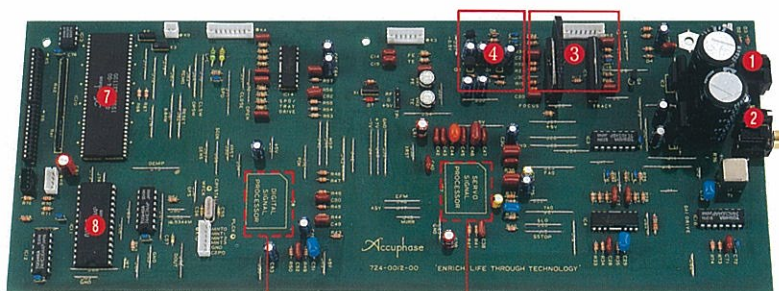

### D/A converter and analog circuit assembly

Assembly including ultra high speed 40 MBit/sec optocoupler, MMB type D/A converter (4 parallel units per channel, on rear side), GIC type Butterworth filter, and floating balanced audio output circuit.

- 9 Unbalanced output connector
- 10 Balanced output connector
- 11 GIC 3-pole analog Butterworth filter
- 12-19 High-precision 20-bit D/A converter (rear side: eight units)
- 20 Ultra high speed optocoupler
- 21 Analog circuit power supply



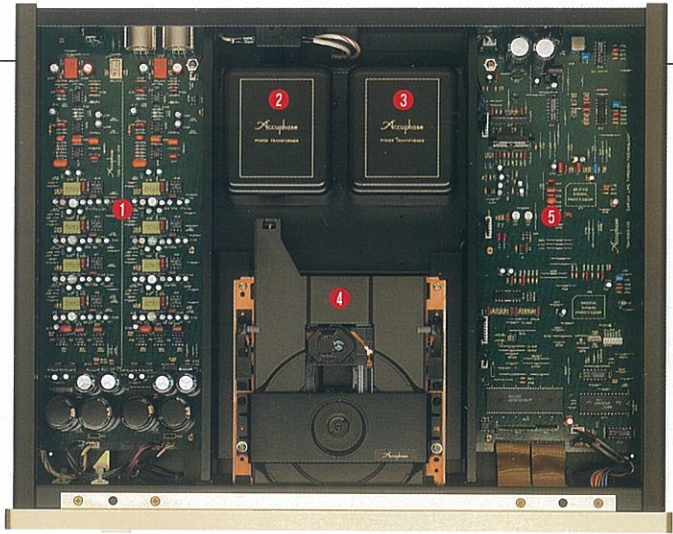
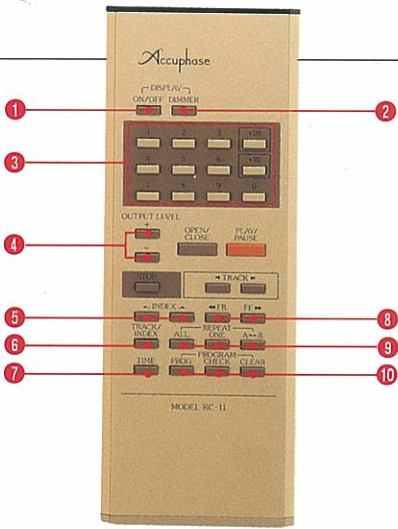

■ Remote Commander RC-11 (Functions not on main unit)

- |                                   |                                     |
|-----------------------------------|-------------------------------------|
| 1 Display On/Off Key              | 6 TRACK/INDEX display switching key |
| 2 Display brightness selector Key | 7 Time display switching key        |
| 3 Direct play keys                | 8 Fast rewind/forward keys          |
| 4 OUTPUT LEVEL adjusting keys     | 9 REPEAT keys                       |
| 5 INDEX search keys               | 10 PROGRAM keys                     |

■ Internal layout

- |  |
|--|
| 1 D/A converter, analog circuit assembly       |
| 2 Power supply transformer for analog circuit  |
| 3 Power supply transformer for digital circuit |
| 4 CD mechanism deck                            |
| 5 Digital circuit assembly                     |





DP-65, all of these requirements are met, and an effective filtering system using common-mode toroidal choke coils and bypass capacitors keeps out AC line noise and RF components. This design also prevents any noise leaks from the DP-65.

**Optical and coaxial digital outputs**

The DP-65 provides digital outputs which let you easily transcribe a CD to a DAT recorder in digital form. There is no need for cumbersome recording level adjustments, and the results will always be nothing less than perfect.

**Laser pickup with integrated RF amplifier for minimum noise**

Since the output level of a laser pickup is

very low, it is highly vulnerable to externally induced noise. To prevent such problems, the pickup used in the DP-65 employs an RF amplifier which is so compact that it can be directly integrated in the pickup assembly. This assures that the high-level output signal remains free from noise interference, which in turn reduces the error rate.

**Balanced drive circuitry for servo motors**

The motors and actuators which drive the disc tray, spindle, sled, and the focussing and tracking assembly require a rapidly fluctuating drive current, depending on the given load condition. Such current fluctuations can affect other circuit areas and cause sound quality degradation. In the DP-65, two amplifiers arranged in a bal-

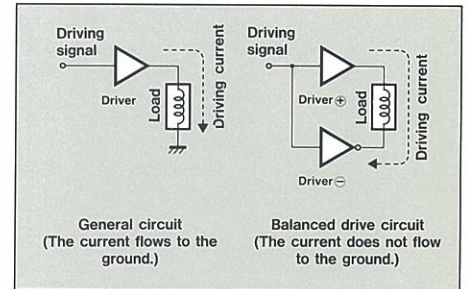

anced configuration provide the drive currents to all these actuators and motors. Because there is no current flowing in the ground line, the operation of other circuits in the player remains entirely unaffected.

**Tray-lock mechanism prevents resonances**

If the disc tray is disengaged from the rotating assembly while the disc is playing, resonances might be created can degrade the signal quality. The disc tray of the DP-65 therefore is firmly locked in place during playback, to eliminate any possibility of harmful resonances.

**Completely balanced circuitry**

The audio output section features completely balanced circuitry whose operation does not depend on the ground line. Any noise that may be induced in the signal path will be canceled out, so that the playback sound remains utterly pure and undiluted. For utmost flexibility, balanced XLR connectors as well as unbalanced RCA-type connectors are provided.



**Power-on play feature and frame display**

"Power-on play" means that the DP-65 can start playback automatically when the power is turned on. This allows automatic playback in conjunction with a timer. For precise location of any spot on a disc, the DP-65 can display frame information (1 frame = 1/75 second), and frame search and repeat are also possible.

**Supplied full-function remote commander**

The supplied remote commander RC-11 is highly convenient, since it can operate all functions, including direct play, repeat and program play. It can even control the display brightness.

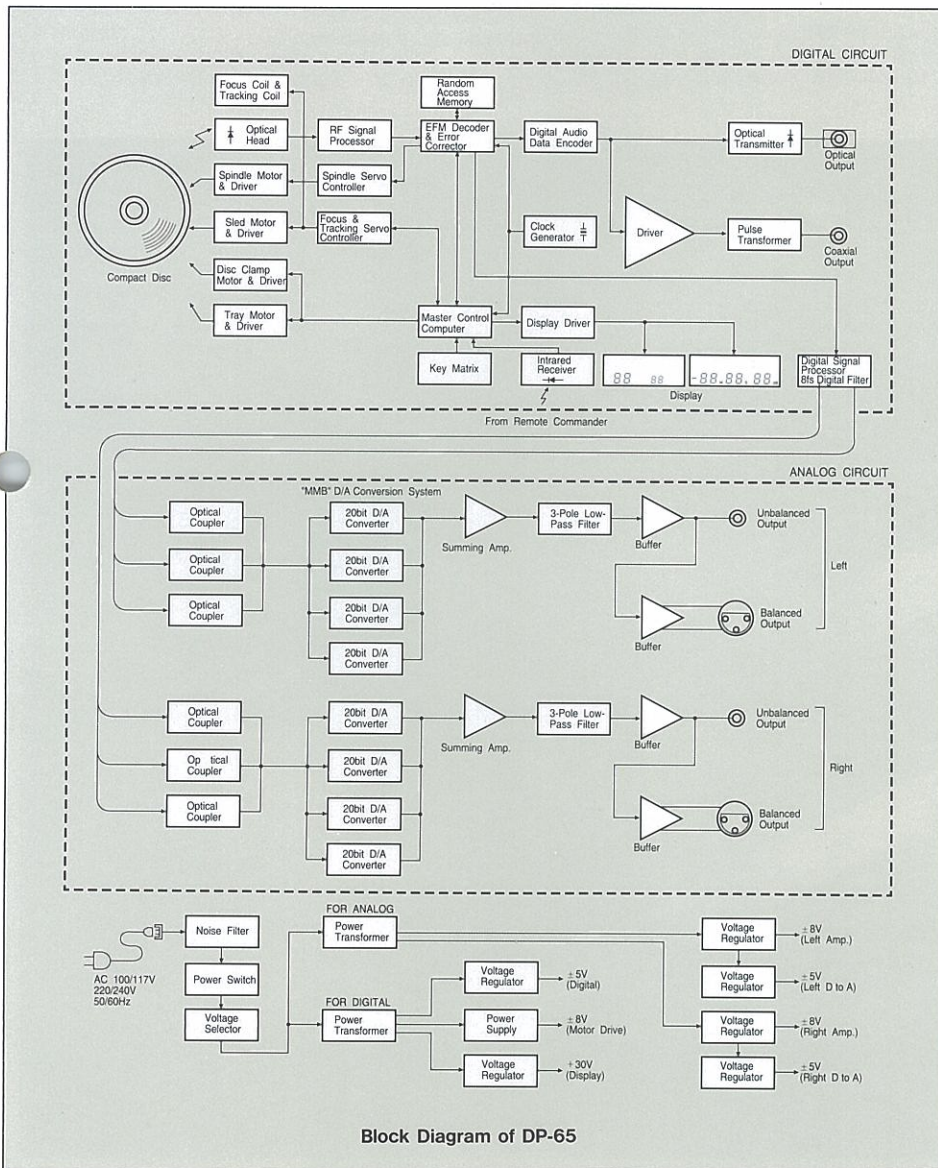

Block Diagram of DP-65



■ FRONT PANEL

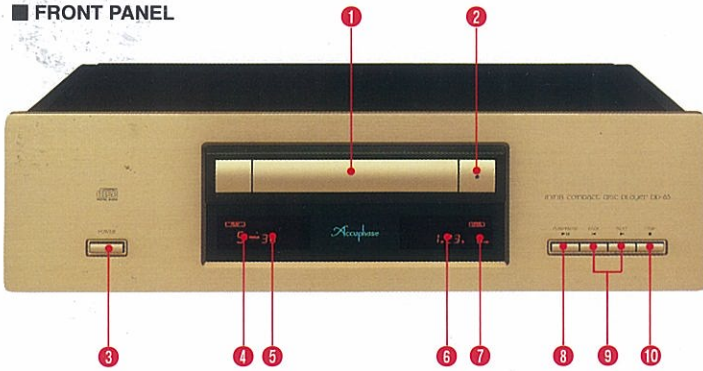

- 1 Disc Tray
- 2 Disc Tray OPEN/CLOSE Key
- 3 POWER Switch
- 4 PLAY TRACK Indicator
- 5 TRACK/INDEX Indicator
- 6 TIME Indicator
- 7 LEVEL/-dB Indicator
- 8 PLAY/PAUSE Key
- 9 TRACK SEARCH Keys
- 10 STOP Key
- 11 Coaxial digital output connector
- 12 Toslink optical fiber output connector

■ REAR PANEL

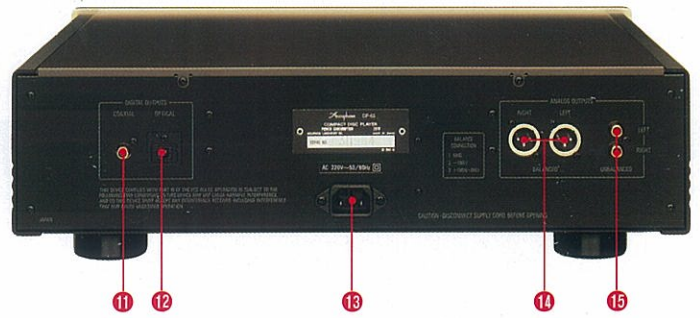

- 11 AC connector (for supplied power cord)
- 12 Balanced type output connector for audio output:
  - 1 Ground
  - 2 Inverted(-),
  - 3 Non-inverted(+),
- 13 Unbalanced type output jack for audio output

GUARANTY SPECIFICATIONS

(Guaranty specifications are measured according to EIAJ standard CP-307)

**Performance Guaranty:**

All Accuphase product specifications are guaranteed as stated.

- **Type:**  
CD digital signal player
- **Format:**  
Compact disc standard format  
Number of quantizations: 16 bits  
Sampling frequency: 44.1 kHz  
Error correction method: CIRC  
Number of channels: 2  
Spindle speed: 200 to 500 rpm  
Scan velocity: 1.2 to 1.4m/s
- **Data read:**  
Non-contact optical pickup (semiconductor laser pickup)
- **Laser:**  
GaAlAs (double heterodyne diode)
- **Frequency characteristics:**  
4.0 to 20,000Hz ± 0.3dB
- **D/A converter:**  
MMB type, 20 bits
- **Digital filter:**  
20 bits, Eight-time oversampling  
Digital deemphasis function  
Deviation: ± 0.001dB
- **Total harmonic distortion:**  
0.0025% (20 to 20,000Hz)
- **Signal-to-noise ratio:**  
118dB
- **Dynamic range:**  
98dB
- **Channel separation:**  
106dB
- **Output voltage and Impedance:**  
Balanced: 2.5V at 50 ohms balanced XLR type  
Unbalanced: 2.5V at 50 ohms, RCA phono jack

- **Digital level control:**  
0 to -40dB, 1 dB steps
- **Digital output format level:**  
Format: digital audio interface  
Optical: output -21 to -15 dBm (EIAJ)  
wavelength:660nm  
Coaxial: 0.5Vp-p at 75 ohms
- **Power requirements:**  
Voltage:100V, 117V, 220V, 240V AC,50/60Hz
- **Power consumption:**  
20W

- **Maximum Dimensions:**  
475mm (18 11/16") width, 140mm (5 1/2") height,  
385mm (15 8/32") depth
- **Weight:**  
15.6kg (34.4 lb.) net  
20.2kg (44.5 lb.) In shipping carton
- **Supplied remote commander RC-11:**  
Remote control system: Infrared pulse  
Power requirements: 3V DC with two  
batteries IEC designation R03 (size AAA)  
Dimensions: 66mm width (2 1/2"),  
175mm height (6 15/16"),  
20mm depth (11/16")  
Weight: 210g (including batteries)

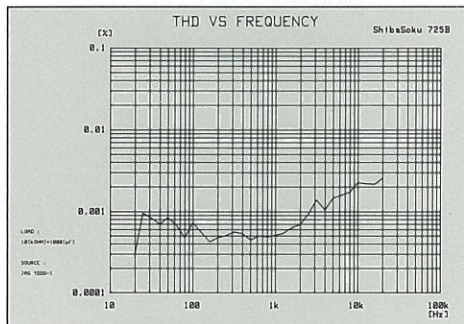

THD vs. frequency

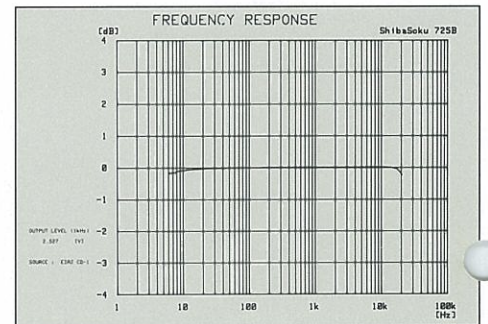

Frequency response

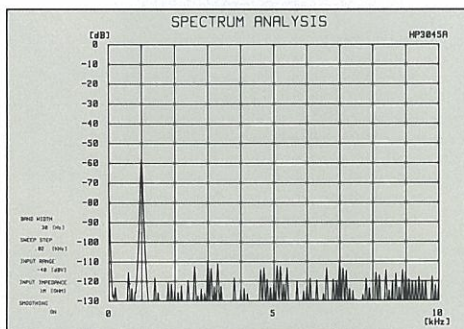

1 kHz, -60dB signal reproduction frequency spectrum

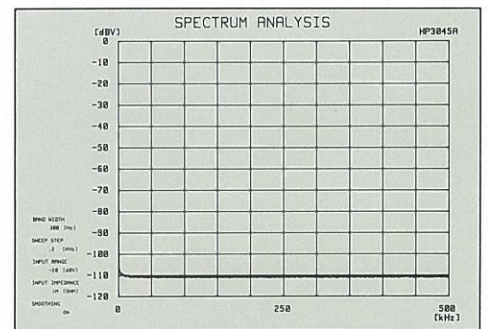

No-signal noise frequency spectrum



ACCUPHASE LABORATORY INC.

PRINTED IN JAPAN K9310Y 851-0117-00(AD-1)