

Accuphase

DIGITAL VOICING EQUALIZER

DG-28

- Voicing equalizer with fully digital signal processing
- 64 filter cells connected in parallel
- High-precision adjustment in 64 frequency bands, using 1/6-octave spacing
- Large display panel shows graphical frequency response curve
- Built-in analyzer and sound field compensation functions
- Automatic measurement and adjustment
- Option boards allow connection of analog equipment
- Supplied remote commander



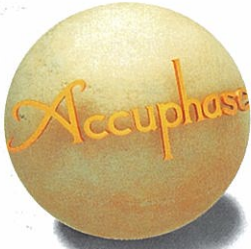

The Digital Voicing Equalizer DG-28 has the power to effectively reshape your listening environment. It uses ultra high-speed DSP chips and super advanced digital signal processing technology to measure the sound field at the listening position and to compensate for any acoustic deficiencies. Internally, the DG-28 operates entirely in the digital domain. Highly precise pin-point adjustments are possible thanks to 64 parallel-connected filter cells per channel, yielding 64 frequency bands spaced only 1/6 octave apart. A large LCD panel provides an intuitive graphic view of frequency response and adjustment settings. Rear-panel option board slots allow connection of analog equipment as well.

What Is a "Voicing Equalizer"?

This somewhat unusual term was chosen to symbolize the advanced capabilities of the DG-28. While this product is a full-fledged high-precision graphic equalizer in its own right, it also incorporates a sophisticated system for automatic sound field compensation. It divides the audible frequency range into distinct bands (voices), and lets the user choose a target response curve that is then expressed (voiced) by the unit through a process of precise measurement and adjustment steps. The result is full control over frequency response characteristics at the listening position.

Development of the Digital Voicing Equalizer DG-28 was made possible by Accuphase's advanced knowledge of digital signal processing technology for pure audio applications. Without suffering any degradation in signal quality, precise sound field control has now become a reality. And what's more, the DG-28 is amazingly simple and intuitive to use. To achieve truly superior music reproduction in a home environment, the characteristics of the speakers as well as the listening room itself have to be taken into consideration. Only when these aspects are under control, the stereo sound stage will come alive in all its splendor. The DG-28 lets the natural ambience and musical presence of the source material emerge with unrivaled clarity and authority.

The DG-28 not only has the power to adjust and fine-tune frequency response, it also incorporates a signal tone generator and comes with a dedicated measurement microphone of high quality, allowing automated adjustment of overall response characteristics. Ultra-precise digital filters provide 1/6-octave resolution, dividing the audio spectrum into 64 frequency bands, something that invariably involved a quality penalty when implemented in the analog domain. A large liquid-crystal display panel shows response in graphical form, making adjustments immediately evident at a glance. In conjunction with the Digital Preamplifier DC-300, the DG-28 comes really into its own. With this combination, the signal remains entirely in the digital domain, right up to the preamplifier outputs. Signal degradation is totally absent. Optional option boards can be used to accommodate a wide variety of analog equipment as well.

Fully Digital Equalizer

As can be seen from Figure 1, sophisticated digital signal processing technology is used in the DG-28 in order to integrate two main functions, namely

sound field measurement and compensation. If analog circuits were employed here, a number of problems were bound to arise, such as component aging, changing circuit characteristics due to fluctuations in ambient temperature, circuit tuning imprecisions, sound quality deterioration depending on adjustment position, etc. The digital approach on the other hand does away with all these problems. It also is highly impervious to externally induced noise. The type of narrow and precise filters that are required for frequency adjustment can be designed very effectively, using DSP (Digital Signal Processor) chips. To assure absolutely top-level performance, the DSP data path in the DG-28 is 24 bit wide for input/output and 48 bit for internal processing. The ultra high-speed DSP chips require no more than 40 nanoseconds for an arithmetic operation. Two such chips are used per stereo channel, resulting in a total complement of four processors.

64 Filter Cells per Channel Connected in Parallel

Filter cells are a vital area of any equalizer, because they determine characteristics such as center frequency and level range. The DG-28 uses a full 64 cells per channel. In the world of automobiles, it might be likened to a 64-cylinder engine, which is why Accuphase likes to call this part the "filter engine". Within this analogy, the DG-28 can be described as having two filter engines, one for each channel.

Internally, the filter cells are connected in parallel, as illustrated by Figure 2. This type of connection has various advantages for a multi-stage filter. Calculation errors will not add up, and any tolerances will be averaged out, thereby reducing noise.

Accuphase has developed special algorithms for linking and controlling operation of the filters.

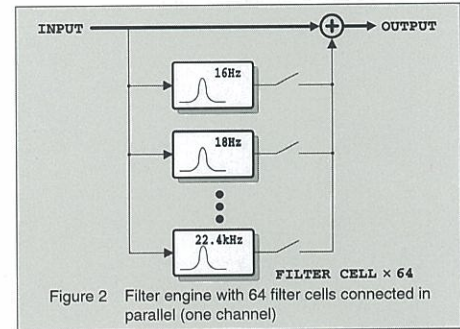

Figure 2 Filter engine with 64 filter cells connected in parallel (one channel)

Currently unused filter cells are removed entirely from the signal path, to preclude any possibility for signal quality deterioration.

High Precision Adjustment From 16 Hz - 22,400 Hz in 1/6-Octave Steps (64 Frequency Bands) or 1/3-Octave Steps (32 Frequency Bands)

Almost all listening rooms are shaped in rectangular fashion, with walls meeting at right angles. This gives rise to standing waves which are an acoustically highly undesirable phenomenon. Especially in the area of 200 Hz and below, drastic frequency response irregularities are very common. In the medium and high frequency range, often the speaker units themselves have response curves which look like a succession of peaks and dips. The DG-28 can even out such irregularities, bringing the response curve much closer to the ideal shape. This is possible because the audio spectrum is divided into 64 bands,

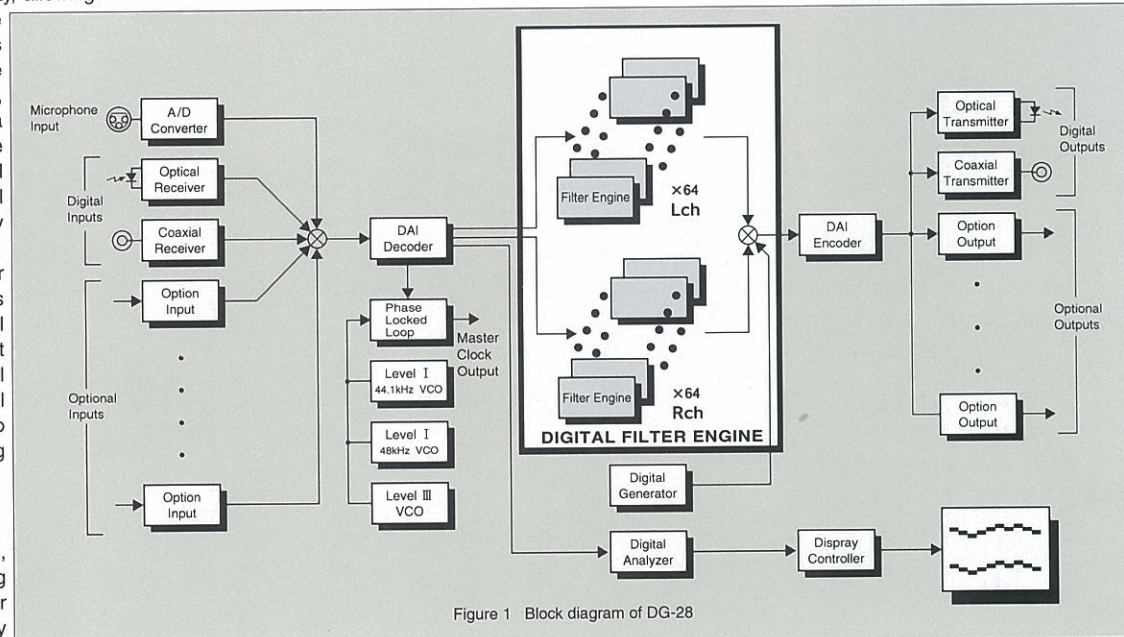

Figure 1 Block diagram of DG-28



allowing pin-point control that is far beyond the scope of conventional equalizers. If desired, operation of the DG-28 can also be switched to 1/3 octave resolution, resulting in 32 frequency bands.

High-Precision Level Adjustment in Each Range, From +12 dB to -12 dB in 0.5-dB Steps

Gain in each of the frequency bands of the DG-28 can be adjusted over a range from +12 dB to -12 dB, in precise 0.5-dB steps.

Ultra Jitter-Free PLL Circuit

The operation of the D/A converter must be synchronized with the digital audio interface (DAI) signal. For this purpose, a phase-locked loop (PLL)

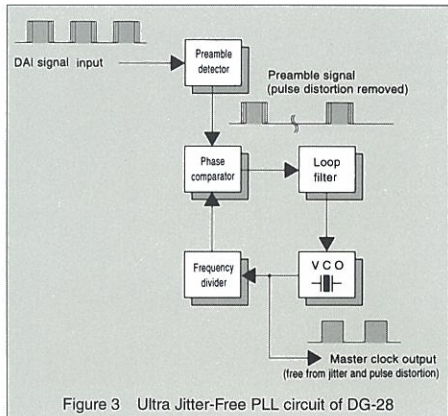
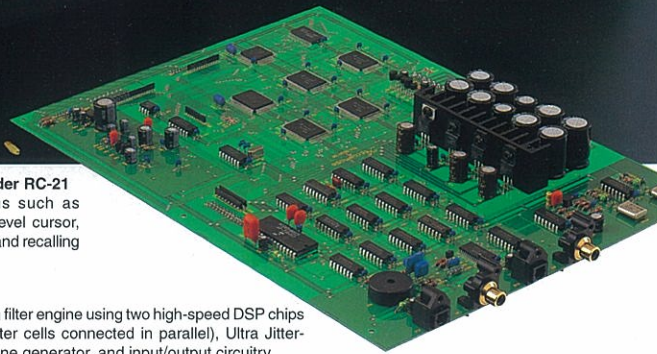

Figure 3 Ultra Jitter-Free PLL circuit of DG-28



■ **Supplied remote commander RC-21**
Allows control of functions such as moving the frequency and level cursor, switching the display, storing and recalling equalization curves, etc.

■ **Main assembly with filter engine using two high-speed DSP chips per channel (64 filter cells connected in parallel), Ultra Jitter-Free PLL circuit, tone generator, and input/output circuitry**



circuit generates a master clock which is used as system reference. In the DG-28, as Figure 3 shows, the Ultra Jitter-Free PLL circuit developed by Accuphase is used. This consists of a detector for the preamble component (a kind of start marker for the L/R signal) and a voltage-controlled oscillator (VCO) using a quartz crystal element. The master clock produced by this PLL circuit is totally free from the effects of pulse distortion and jitter.

Outstanding Signal-to-Noise Ratio and Channel Separation

With equalizers using analog circuitry, S/N ratio and channel separation invariably deteriorate as frequency characteristics are adjusted. This kind of degradation is totally absent in the DG-28, thanks to its all-digital design.

Large LCD Screen With Graphical Display Makes Adjustments Easy and Intuitive

The display is a large, easy-to-read LCD panel with a resolution of 320 x 240 dots. The equalization curve clearly shows measurement results and compensation settings in the 64 frequency bands. When not needed, the display can be turned off, and a contrast control is also provided. If desired, a beep tone gives audible feedback when controls are operated.

The display of the DG-28 offers three distinct operation modes:

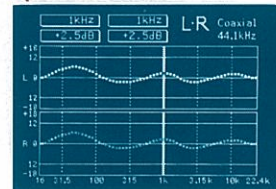

Equalizer mode

This is the standard display which can be used to call up, modify, and store equalization curves.



Environment setting mode

This screen serves to select input sources and make settings such as beep tone on/off, display function, attenuator level etc.

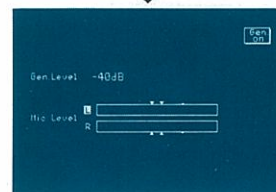

Analyzer mode

The sound field measurement and compensation process is initiated from this screen.

The DG-28 incorporates analyzer and sound field compensation functions. Using a built-in test signal tone generator and a supplied microphone, the acoustic properties of the listening room can be measured and corrected automatically.

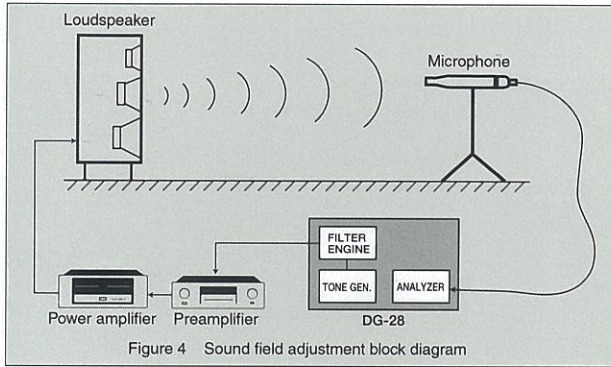

Built-In Digital Tone Generator and Analyzer

Adjusting the controls of an equalizer by ear has its limitations. In order to perform precise compensation, a signal tone generator and a frequency analyzer are required. The DG-28 already provides all of these elements.

Figure 4 shows the principle of sound field measurement and compensation as performed by the DG-28. For measurement, the tone generator output is connected to the filter engine which in turn supplies the signal to the preamplifier and power amplifier, to drive the loudspeakers. The reproduced sound is picked up by the microphone placed at the listening position, and the signal from the microphone is supplied to the frequency analyzer in the DG-28. This allows measuring the overall response of the reproduction system in its normal state, with all components connected and working as they would normally.

For the measurement, a so-called warble tone (a signal which fluctuates over a very narrow frequency range) is used. By sweeping this signal over the entire audio frequency range, precise acoustic measurements can be made in a short time, without adverse influences from extraneous noise. Because both the tone generator and the frequency analyzer are digital circuits implemented by a DSP, highly sophisticated algorithms developed by Accuphase can be used, assuring precise and stable operation as well as exact reproducibility.

Automatic Compensation of Sound Field Characteristics

Because the DG-28 is a precision equalizer with 64 distinct frequency bands per channel, adjusting the response curve entirely by hand would require a considerable amount of time and expertise. While this is an option that can be chosen if desired, the DG-28 also offers another way, namely automatic adjustment using special algorithms developed by Accuphase. By following the simple steps listed below, the sound field at the listening position can be quickly and effectively optimized.

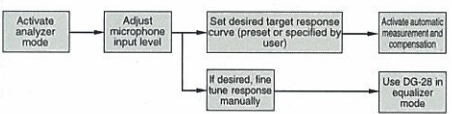

The time required for the above process will vary somewhat, depending on the speakers and the listening room conditions. A representative figure is

about five to six minutes per channel. For even higher precision, it is possible to repeat the measurement as often as desired and average the results. Figure 5 shows an example for automatic measurement and compensation with "flat" target response. The peaks and dips caused by listening room and speaker irregularities are evened out, resulting in a response curve that is much more linear.

Manual Fine Tuning Possible

After automatic adjustment is completed, the user has the option to fine-tune settings in each 1/6-octave band. It is also possible to perform the entire measurement and adjustment process manually if desired.

Doubles as Sound Field Evaluation Tool

Another use for the DG-28 is as a tool in performing a sound field measurement only, without providing any compensation. This comes in handy for example to evaluate the characteristics of a loudspeaker or the listening room, or to adjust a multi-amped system.

Up to 4 Sets of Measurement Data Can Be Stored

Four response curves can be stored and recalled at the touch of a button, which is handy for example to apply different equalization to different music genres, driving different sets of loudspeakers, making quick comparisons of equalization effects, etc.

Supplied Microphone With Controlled Frequency Response

For sound field measurements, a high-quality microphone with wide and flat frequency response is a must. The DG-28 therefore comes with the 1/4-inch type back-electret condenser microphone AM-28. The ultra-thin diaphragm of this microphone

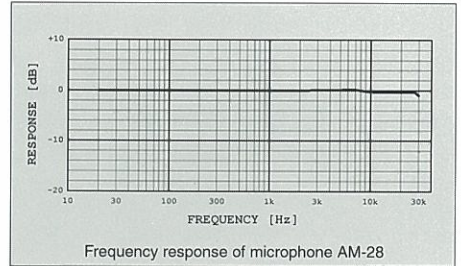

assures linear response over a wide range, allowing accurate measurement and compensation.



Measurement microphone including cable (5 m) and holder

If adjustment is performed so as to achieve fully flat frequency response at the regular listening position, the audible result will be felt to be very bright. Normally, a gradually declining curve towards the upper frequency region is preferable. Therefore the DG-28 incorporates three preset rolloff characteristics, with 1 dB, 2 dB and 3 dB attenuation per octave, starting at 2 kHz. Alternatively, the user can also specify any desired response curve.

■ Selecting the desired target response

L channel

Equalizer off (before compensation)

R channel

Equalizer off (before compensation)

L channel

Equalizer on (after compensation)

R channel

Equalizer on (after compensation)

Figure 5 Example for automatic measurement and compensation (target response: flat)

Interfacing the DG-28 With Other Equipment

Optical and Coaxial Inputs and Outputs Allow Direct Digital Connection to DC-300

The DG-28 is equipped with two sets of digital input/output connectors, accommodating both fiber-optic and coaxial links. Because the Digital Preamplifier DC-300 from Accuphase offers has EXT DSP connectors, the DG-28 can be directly inserted in the signal path, remaining entirely within the digital domain. Only immediately before the preamplifier outputs, the signal is converted into analog form.

Other digital sources such as a CD transport, DAT or MD recorder or similar can also be connected directly to the digital inputs of the DG-28. The output from the DG-28 may then be supplied to a high-quality digital-to-analog converter. Option board slots on the rear of the DG-28 assure system flexibility, allowing the user to increase also the number of digital input and outputs when required.

Analog Equipment Can Be Connected Via Option Boards

For connection to analog components, analog input and output boards can be installed in the DG-28. This allows connection for example in the tape monitor loop (TAPE REC and PLAY) of a preamplifier or integrated amplifier. Connection between a preamplifier and power amplifier is also possible. Using analog line input boards, feeding the output of a CD player or tuner into the DG-28 is another possibility. A line output board can then be used to supply the equalized signal to the line input of a preamplifier. To maintain the outstanding sound quality level that is the hallmark of the DG-28, state-of-the-art converters mounted on the option boards turn the signal into digital form for processing and back into analog form for output.

Slots for Up to Four Boards

A wide array of input and output boards is available from Accuphase to meet the needs of the professional and high-end user. All boards install easily in four rear-panel slots conforming to the Accuphase Digital Bus (ADB) interface standard.

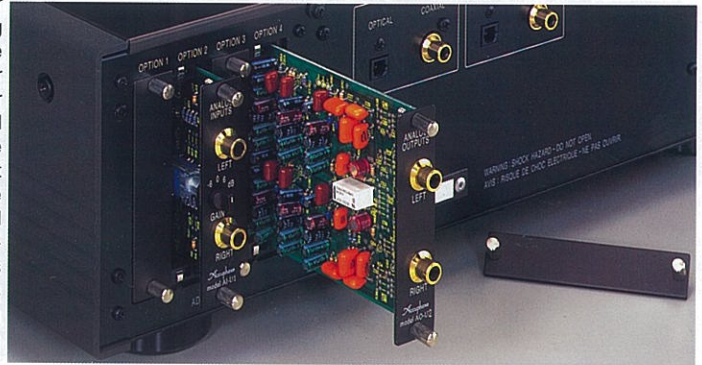

Option Boards

- Any board can be installed in any empty slot.
- All boards use the Accuphase Digital Bus (ADB) Interface.

The DG-28 is a fully digital voicing equalizer, but using option boards inserted in dedicated slots on the rear of the unit, it can accept signals also from analog equipment and output analog signals to such equipment. This allows use in the same way as a conventional graphic equalizer. Various option boards to expand the number of digital inputs and outputs are also available.

Analog Option Boards



For analog input:

Line Input Board AI-U1

Unbalanced high-level input
Suitable for input of the analog signal from a component such as a CD player, tuner, tape recorder or similar.

- ★ The analog input signal is converted to a high-precision digital signal by a 20-bit, 5-pole Delta-Sigma A/D converter with 64-times oversampling.

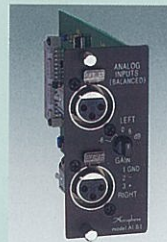

For balanced analog input:

Balanced Input Board AI-B1

Balanced high-level input

- ★ Suitable for the analog signal from the balanced output of components such as a CD player, tuner, tape recorder or similar.
- ★ The analog input signal is converted to a high-precision digital signal by a 20-bit, 5-pole Delta-Sigma A/D converter with 64-times oversampling.



For analog output:

Line Output Board AO-U2

Unbalanced high-level output

- ★ The signal from the DG-28 is converted to an analog signal by a high-precision MMB type D/A converter on the board.
- ★ The board has a higher output voltage rating than the Line Output Board AO-U1.
 - D/A converter : 20 bit, 4 MMB principle
 - Digital filter : 20 bit, 8-times oversampling
 - Max. output voltage : 5.0 V

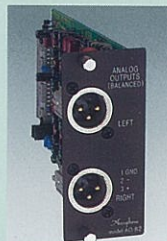

For balanced analog output:

Balanced Output Board AO-B2

Balanced high-level output

- ★ The signal from the DG-28 is converted to an analog signal by a high-precision MMB type D/A converter on the board.
- ★ The board has a higher output voltage rating than the Balanced Output Board AO-B1.
 - D/A converter : 20 bit, 4 MMB principle
 - Digital filter : 20 bit, 8-times oversampling
 - Max. output voltage : 5.0 V

For analog input/output:

Line Input/Output Board AIO-U1

Unbalanced input and output

For playback of analog records:

Analog Disc Input Board AI-AD1

High-performance, high-gain phono equalizer board for use with an analog record player.

Digital Option Boards

For BNC coaxial input:

BNC Coaxial Input Board DI-BNC1

For coaxial cable (75 ohms) with BNC connector

For HPC optical input:

HPC Optical Input Board DI-ST1

For connection of ST type HPC optical link
★ HPC optical fiber cables (HLG-10 etc.) are available from Accuphase.

To add digital inputs/outputs:

Digital Line Input/Output Board DIO-OC1

Provides coaxial and optical inputs and outputs for digital signals

For professional standard input/output:

AES/EBU Input/Output Board DIO-PRO1

Provides a balanced XLR input and outputs for digital signals corresponding to professional AES/EBU specifications.

- ★ HPC optical fiber cables (HLC-10 etc.) are available from Accuphase.

1/3 Octave and 1/6 Octave Center Frequencies

An octave in musical theory is an interval between two musical notes one of which has twice the pitch of the other and lies eight notes away from it. In terms of frequency, this means either twice the frequency or half the frequency. For example, using 1 kHz as a reference, 1 octave higher is 2 kHz and one octave lower is 500 Hz.

When the DG-28 operates in 1/6 (1/3) octave mode, it divides one octave into six (three) sections of equal pitch spacing. This means that the division does not consist of six equal frequency steps but rather uses a factor of $2^{1/6}$ ($2^{1/3}$) as referred to the center frequency.

Center frequencies for 1/6 octave and 1/3 octave spacing as defined by the ISO (International Standards Organization) are shown in the table.

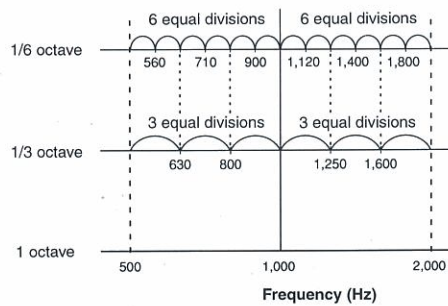

Center frequencies for 1/6-octave and 1/3-octave operation (ISO standard)

1/6octave	1/3octave	1/6octave	1/3octave	1/6octave	1/3octave	1/6octave	1/3octave
16Hz	○	100	○	630	○	4.0	○
18	○	112	○	710	○	4.5	○
20	○	125	○	800	○	5.0	○
22.4	○	140	○	900	○	5.6	○
25	○	160	○	1kHz	○	6.3	○
28	○	180	○	1.12	○	7.1	○
31.5	○	200	○	1.25	○	8.0	○
35.5	○	224	○	1.4	○	9.0	○
40	○	250	○	1.6	○	10.0kHz	○
45	○	280	○	1.8	○	11.2	○
50	○	315	○	2.0	○	12.5	○
56	○	355	○	2.24	○	14.0	○
63	○	400	○	2.5	○	16.0	○
71	○	450	○	2.8	○	18.0	○
80	○	500	○	3.15	○	20.0	○
90	○	560	○	3.55	○	22.4	○

Q (Filter Curve Steepness)

Q (quality factor) is a measure of the steepness of a peak or dip in the response curve of a component or filter. Taking the frequency at the tip of the peak as f and the frequency difference between the points on both sides where response has dropped by 3 dB as Δf , Q is calculated as follows:

The steeper the curve, the smaller will Δf be, resulting in higher Q. The DG-28 implements the constant-Q principle which minimizes unwanted influences on neighboring frequency bands. Q also does not change at various level settings.

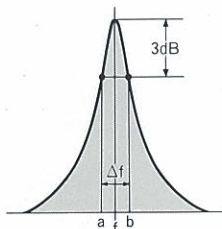

$$Q = \frac{f}{\Delta f}$$

f: Frequency at peak
 Δf : b-a, frequency differential between points where response has dropped by 3 dB

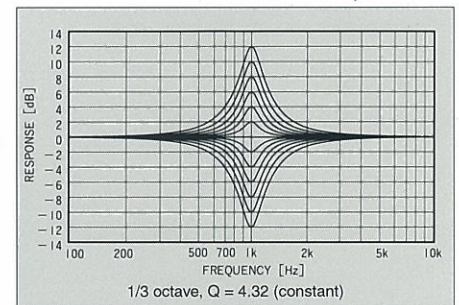
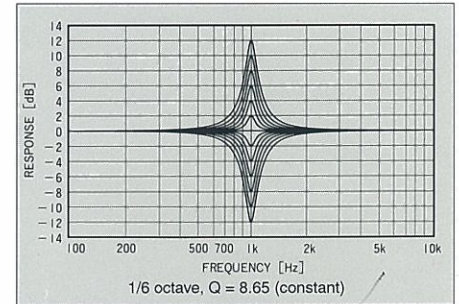

Front panel

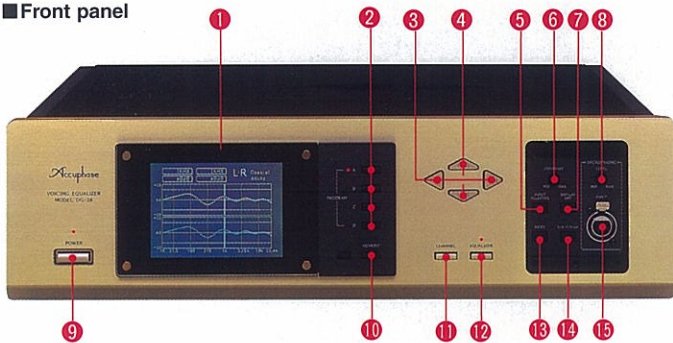

Supplied accessories

- * Microphone AM-28
- * Microphone cable (5 m)
- * Microphone holder
- * Remote commander RC-21
- * 75-ohm coaxial cable (2)
- * Power cord

Rear panel

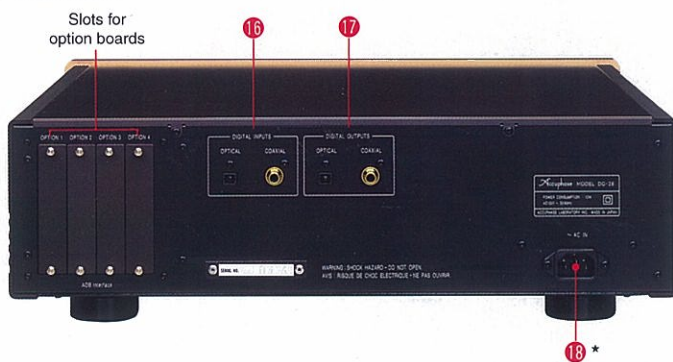

- | | |
|---------------------------------------|--|
| 1 Display | 10 Memory button |
| 2 Program buttons A, B, C, D | 11 Channel selector |
| 3 Frequency cursor left/right buttons | 12 Equalizer on/off button |
| 4 Level cursor up/down buttons | 13 Mode selector (L, R, L/R) |
| 5 Input selector | 14 Octave selector (1/3 oct, 1/6 oct) |
| 6 Contrast control | 15 Microphone input connector |
| 7 Display on/off button | 16 Digital inputs (OPTICAL, COAXIAL) |
| 8 Microphone level control | 18 Digital outputs (OPTICAL, COAXIAL) |
| 9 Power switch | 19 AC power connector (for supplied power cord)* |

Remarks

* The shape of the supplied power cord depends on the voltage rating and destination country.

※ Specifications and design subject to change without notice for improvements.

GUARANTEED SPECIFICATIONS

※ Guaranteed specifications are measured according to EIAJ CPR-2101.

- **Equipment Type**: Digital 1/6-octave 64-band equalizer (switchable to 1/3-octave 32-band)
- **Center Frequencies**: ISO standard, 16 - 22,400 Hz, 64/32 points
- **Q (Filter Curve Steepness)**: 1/6-octave operation: 8.65
1/3-octave operation: 4.32
- **Frequency Response**: 0 - 22.4 kHz ± 0 dB (sampling frequency 48 kHz)
- **Gain**: 0 to -18 dB, variable
- **Digital Inputs**:

Format	: Digital audio interface EIAJ CP-1201
Quantization	: 16 to 24 bit, linear
Sampling frequency	: 32 kHz, 44.1 kHz, 48 kHz (auto detect)
OPTICAL input level	: -27 to -15 dBm
COAXIAL input level	: 0.5 Vp-p, 75 ohms
- **Digital Outputs**:

Format	: Digital audio interface EIAJ CP-1201
Quantization	: 24 bit, linear
Sampling frequency	: same as input
OPTICAL output level	: -21 to -15 dBm (wavelength 660 nm)
COAXIAL output level	: 0.5 Vp-p, 75 ohms
- **Power Requirements**: 100 V, 120 V, 220 V, 230 V, 240 V (Voltage as indicated on rear panel) AC, 50/60 Hz
- **Power Consumption**: 12 watts
- **Maximum Dimensions**: 475 mm (18-11.16") width
150 mm (5-7/8") height
393 mm (15-1/2") depth
- **Weight**: 13 kg (28.7 lbs.) net
20 kg (44.1 lbs.) in shipping carton
- **Supplied Remote Commander RC-21**:

Remote control principle	: infrared pulse
Power supply	: 3 V DC, IEC R6 (size AA) batteries x 2
Dimensions	: 45 mm width (1-3/4") 136 mm height (5-3/8") 18 mm depth (11/16")
Weight	: 85 g (including batteries)

Accuphase
 ACCUPHASE LABORATORY INC.

PRINTED IN JAPAN F9710Y 851-0150-00(AD1)