

Accuphase

A-100

MONOPHONIC POWER AMPLIFIER

- Pure Class A Operation Delivers 100 W of Quality Power (into 8 ohms)
- Totally Balanced Design with Two Separate Unit Amplifiers and Power MOSFETs in a 10-Parallel Push-Pull configuration
- Hybrid IC Input Stage Assures Superior Performance and Reliability
- Extra-Large Speaker Terminals Allow Biwiring
- Balanced Input



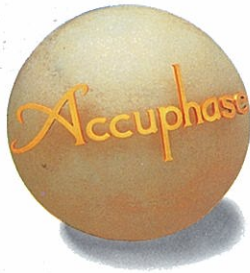

Power MOSFET Output Stage with Two Units in a 10-Parallel Push-Pull Configuration and Symmetrical Connection for Totally Balanced Architecture. Pure Class A Operation Delivers 100 Watts of Quality Power into 8 Ohms. Superb Drive Capability for Low-Impedance Loads, with Ideal Power Progression of 200 Watts into 4 Ohms and 400 Watts into 2 Ohms. Balanced Input Stage with Hybrid IC for Outstanding Performance and Long-Term Reliability.

The A-100 is an ultimate-quality component that represents everything Accuphase stands for. The entire wealth of Accuphase's accumulated know-how is incorporated in this pure class A monophonic power amplifier, which was designed to redefine the concept of impeccable music reproduction.

In pure class A operation, the power supply delivers a steady current, regardless of the presence or absence of a musical signal. This means that the amplifier is unaffected by external influences and that its operation remains highly stable under all circumstances. But it also means that the output stage generates considerable thermal energy, commonly on the order of more than 200 watts for an amplifier rated at 100 watts output. In the A-100, this figure is as high as 350 watts, and therefore efficient heat dissipation is an absolute necessity. This is why the A-100 possesses massive heat sinks on both sides which have ample capacity to dissipate the heat produced by the internal circuit components.

The guaranteed output power of the A-100 is 400 watts into 2 ohms, 200 watts into 4 ohms, and 100 watts into 8 ohms. As these figures indicate, the relationship between load impedance and output power is identical to the theoretical values. In comparison to some other amplifiers, a rating of 100 watts into 8 ohms may seem small, but since the A-100 will effortlessly drive even speakers of very low impedance, there is absolutely no lack of power in actual operation.

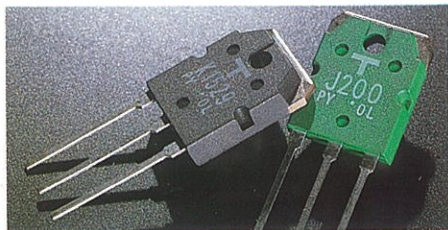

The output stage uses power MOSFET devices in a 10-parallel push-pull arrangement with two separate amplifier units connected in a bridged configuration. The balanced circuit principle is maintained throughout, to assure totally stable speaker drive.

The input stage employs a balanced differential pure complementary push-pull design developed by Accuphase. This allows the direct connection of a balanced input signal. Even with an unbalanced connection, one side of the input is connected to ground, allowing direct connection of the signal without having to use a phase inverter. A newly developed hybrid IC with an alumina ceramic substrate is used in the input stage of the A-100, yielding outstanding temperature stability and long-term reliability.

All energy delivered by an amplifier to the speakers ultimately derives from the power transformer and filtering capacitors of its power supply. In the A-100, an over-dimensioned toroidal transformer with a capacity of a full 1kVA is used, together with two extra-large 68,000 μF capacitors. This results in a wide performance margin and awesome current capacity that is virtually impossible to exhaust. The transformer and capacitors are housed in aluminum diecast enclosures to provide full electrical and mechanical isolation and prevent any possibility of sound quality degradation. In order to support the enormous weight of the power supply and heat sinks, the chassis and front and rear panels of the A-100 are designed to an almost excessive mechanical strength.

The large speaker terminals allow biwiring and pure copper lead wires are employed to complement high-quality. Signal path lines such as printed circuit boards and buss lines made of OFC (oxygen-free copper) are gold-plated for absolutely pure signal transmission.

Every aspect of the A-100 has been finely honed for nothing less than perfection. In a top-quality system, this monophonic power ampli-

fier will create a musical sound stage of awe-inspiring authority.

Power MOSFET Output Stage With Two Units in 10-Parallel Push-Pull Configuration Delivers 400 Watts into 2 Ohms, 200 Watts into 4 Ohms, 100 Watts into 8 Ohms

Fig. 1 shows the circuit diagram of the A-100. The N-channel power MOSFETs (Q_6, Q_8, \dots, Q_{24}) and P-channel power MOSFETs (Q_7, Q_9, \dots, Q_{25}) are arranged in a 10-parallel push-pull configuration. Two such units are connected in a bridged configuration. The rated output power is 100 watts into an 8-ohm load, but since a total of 40 MOSFETs are used in both the units, the total power dissipation is actually an amazing 4 kW, which leaves a more than ample margin. MOSFETs are voltage-controlled devices. Since the carrier of electrons is different from that of bipolar transistors, MOSFETs have good high frequency characteristics and a high switching speed. The temperature coefficient of a MOSFET is negative, which means that the drain current does not increase with temperature, making the MOSFET free from current concentration and thermal runaway. Unlike the bipolar transistor, the second breakdown does not take place in a MOSFET in the high voltage region, and therefore, the MOSFET can guarantee a wide area of safe operation.

In pure class A operation, the current flowing through the active devices is always at the value required for maximum output, and the amplifier consequently produces a considerable amount of heat. The output devices therefore are mounted on a thick aluminum block which in turn is mounted to the extra-large extruded-aluminum heat sink.

Since the A-100 is designed to deliver an absolutely stable output of 100 watts into ohms, its current capability into 4 and 2 ohms corresponds to the theoretical values, with 200 and 400 watts, respectively. Even into a load as low as 1 ohm, the A-100 can deliver 560 watts (measured). This assures stable drive of any kind of speaker, including highly demanding low-impedance types.

Totally Symmetrical and Balanced Circuitry with Two Power Amplifier Units

As illustrated by Fig. 2, there are two general principles for audio signal transmission. Principle (a) is the so-called unbalanced principle used in conventional audio components. (b) is the principle of balanced signal transmission which employs two identical amplifiers. The circuit configuration of (a) is simpler, but there is a distinct possibility of external noise being picked up by the signal ground line, which can lead to sound quality degradation. In the balanced setup, separate lines are required for the positive and negative signals, but any external noise picked up by a signal line is cancelled by principle, and even distortion components arising within the amplifier are cancelled in the output stage, leaving only the pure audio signal. Therefore this is the ideal principle for high-quality performance.

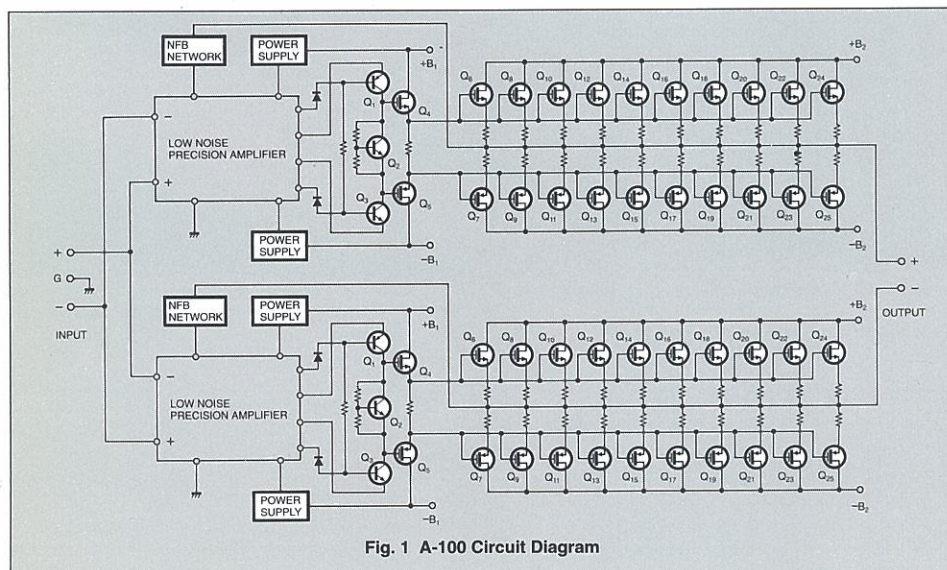
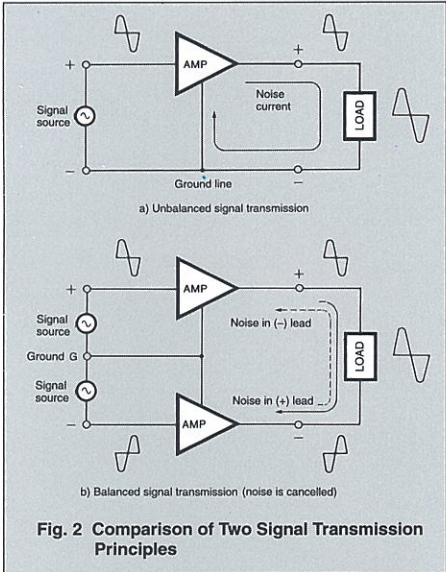

Fig. 1 A-100 Circuit Diagram



In the A-100, two push-pull amplifier units are connected in a bridged configuration throughout, which fully brings out the advantages of balanced signal transmission. When a balanced connection is used, the (+) signal and (-) signal of the inverted and non-inverted amplifiers are input separately, and appear at the output as two phase-inverted signals. With an unbalanced connection, only the signal is supplied to the non-inverted amplifier, while the other is simply grounded. This eliminates the need for a phase inverter or other extraneous

circuitry and achieves highly pure amplification, both in balanced and unbalanced input connections.

Balanced Differential Hybrid IC Input Stage
 The input stage as shown in Fig. 3 employs the balanced differential pure complementary push-pull design developed by Accuphase. The (+) (non-inverted) and (-) (inverted) input circuits each have a FET buffer with high input impedance and low output impedance. A newly developed hybrid IC performs most of the important functions of the input stage. Since these functions are quite complex, the IC

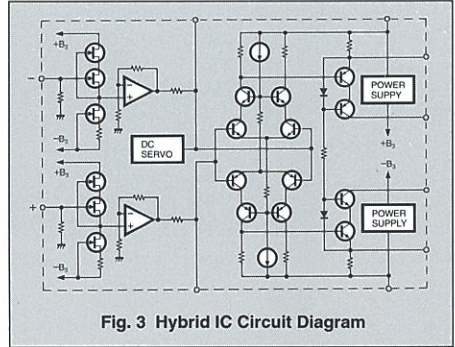

is a fairly large type, measuring 60 x 35 mm. On its alumina ceramic substrate, the circuits are laid out in a complementary symmetrical design. Temperature stability, long-term reliability, resistance to noise, etc. are all outstanding. The entire IC is protected by an aluminum cover, to shut out any external influences.

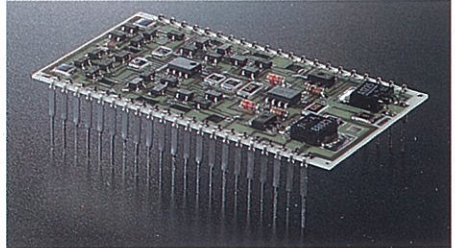

Gold-Plated Signal Paths
 Accuphase always uses a high purity copper to ensure optimum signal path purity. In the A-100, this approach is further enhanced by the use of gold-plating to reduce surface resistance and achieve absolutely smooth current flow. As this is especially important in a power amplifier, Accuphase employs OFC (oxygen-free copper) plates in the circuit which must handle very large current. In addition, gold-plating is applied to the OFC plates in the A-100. The shielded leads of the attenuators employ highly pure wires selected for optimum sonic characteristics.

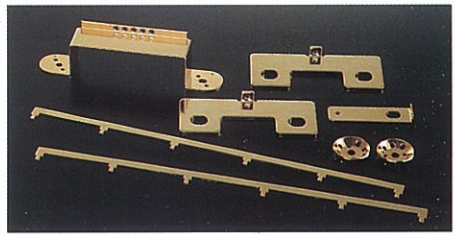

INTERNAL LAYOUT

- 1 Power amplifier unit
- 2 PCB with meter drive and other circuits
- 3 Two 68,000 μ F filter capacitors
- 4 Large toroidal power transformers
- 5 Power amplifier unit

Large heat sinks with attached 10-parallel push-pull outputstage and amplifier unit



Power Amplifier Assembly (Two Units)

- 1 P-channel power MOSFETs in 10-parallel configuration
- 2 P-channel drive MOSFETs
- 3 Stabilizer source resistor
- 4 Drive circuit power supply
- 5 Stabilizer source resistor
- 6 N-channel drive MOSFETs
- 7 N-channel power MOSFETs in 10-parallel configuration
- 8 Pre-drive transistor
- 9 Cover of input stage amplifier hybrid IC
- 10 Gold-plated glass epoxy PCB
- 11 Large heat sink
- 12 Resonance suppression handle

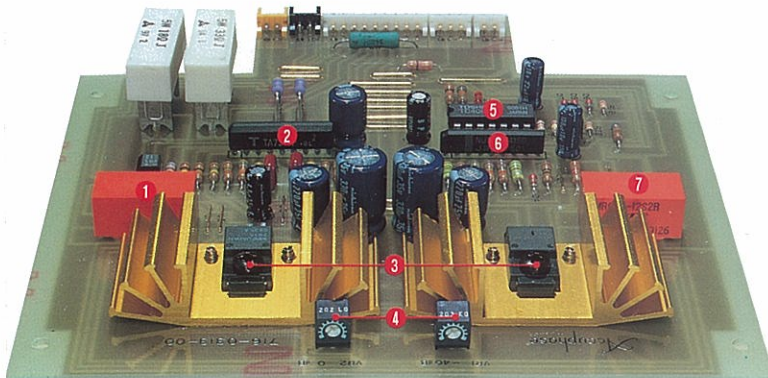

Meter Drive PCB

- 1 Lamp control relay
- 2 Meter drive IC
- 3 Regulator transistor
- 4 Needle angle adjustment trimmer
- 5 Alarm indication IC
- 6 Meter auxiliary circuit IC
- 7 Meter muting relay

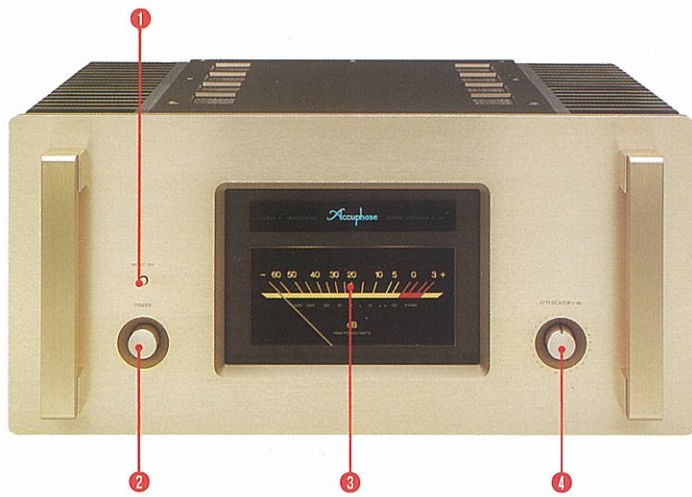

FRONT PANEL

- 1 Power meter on/off switch
- 2 Power switch
- 3 Peak-reading power meter (dB scale, direct wattagescale)
- 4 Input level control (up to -20 dB in 1-dB steps)

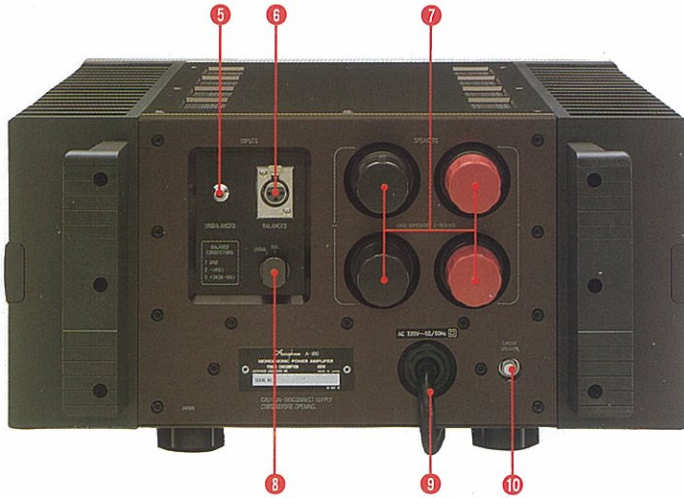

REAR PANEL

- 5 Unbalanced input jack (20 kΩ)
- 6 Balanced input connector XLR-3-31 or equivalent (1): Ground (2): Inverted (-) (3): Non-inverted (+) Suitable connector: XLR-3-12C or equivalent
- 7 Speaker output terminals
- 8 Input selector UNBALANCED, BALANCED
- 9 AC power cord
- 10 Circuit breaker

Heat Sink, Chassis, and Panels Made from Thick Aluminum for Optimum Rigidity

In class A operation, the power transistors of an amplifier produce a considerable amount of heat, which must be effectively dissipated. The A-100 therefore has large heat sinks which have a total volume capacity of a full 16.4 liters and weigh approximately 20 kg. The heat sinks are fin-shaped to intensify natural cooling, and a handle in the center helps to control vibrations. The chassis which serves as a support for the entire amplifier of course is also designed for extra strength, using 9 mm thick extruded aluminum.

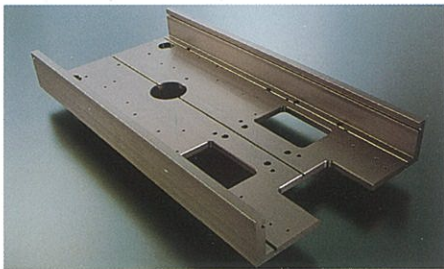

Aluminum Diecast Enclosure for Power Transformer and Filtering Capacitors Ensures Mechanical Stability

The power transformer in the A-100 is a high-efficiency toroidal type encased in a thick aluminum diecast enclosure, to prevent vibrations and other adverse effects from reaching the outside. The enclosure is filled with a vibration suppressing material of high heat conductivity.

The filtering capacitors are also housed in similar cases with a strength of 4 mm, filled with special anchoring material for electrolytic capacitors. Thanks to these precautions, the power transformer and capacitors can work in an optimum environment without affecting other parts of the amplifier.



Extra-Large Speaker Terminals Allow Bi-wiring

The amply dimensioned speaker binding posts of the A-100 can accommodate even very heavy-gauge speaker cables without problems. The terminals are made of a specially pure brass with gold-plating, covered by

molded insulator caps. There are two parallel sets of terminals, to permit biwiring (connecting the low range drivers and mid/high range drivers of a speaker with separate cables). The electrodes are 2 mm thick oxygen-free copper plates which are also gold-plated. The total weight of the speaker terminal assembly alone is more than 1 kg.

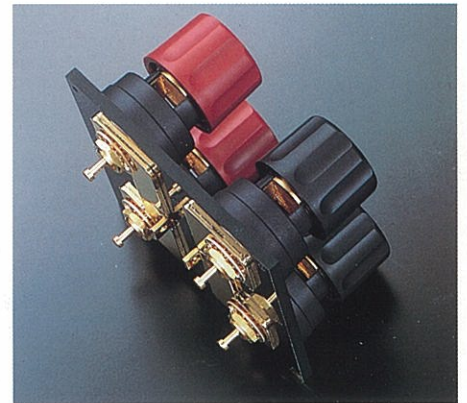

Peak Power Meter Calibrated in Decibel and Watts

The large output level meter employs a logarithmic scale which covers a wide dynamic range. The peak indication allows quick and accurate reading of power levels. The movement and illumination of meter can be turned off by an individual switch.

Like the still surface of a lake
 Reflecting the landscape
 In the serenity of nature
 Such is the purity of Class A

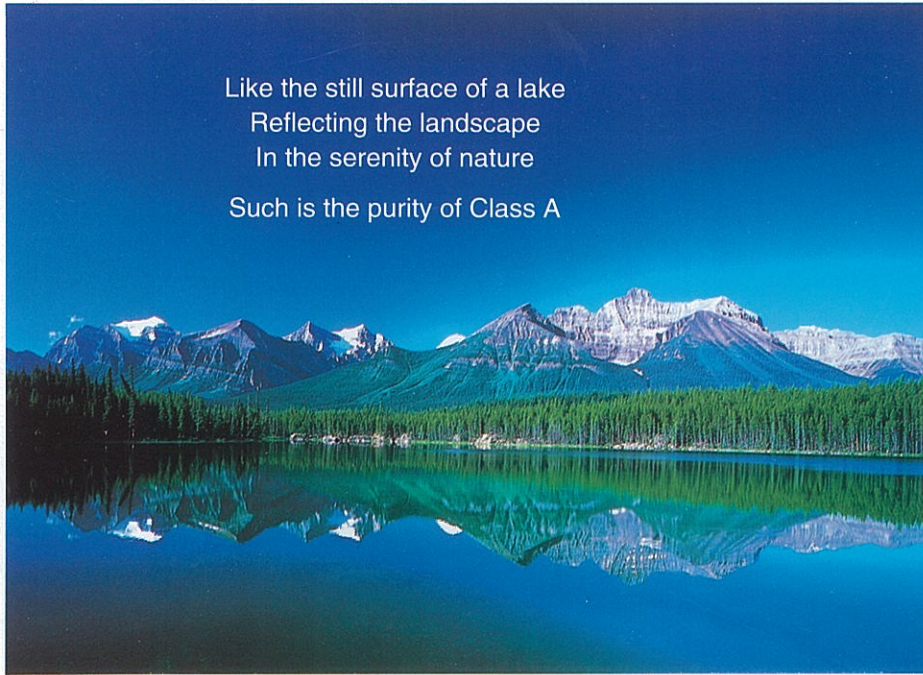

enrich life through technology

GUARANTY SPECIFICATIONS

(Guaranty specifications are measured according to EIA standard RS-490.)

Performance Guaranty

All Accuphase product specifications are guaranteed as stated.

• **Continuous Average Output Power (20 to 20,000 Hz)**

- 400 watts into 2-ohm load
- 200 watts into 4-ohm load
- 100 watts into 8-ohm load
- 50 watts into 16-ohm load

• **Total Harmonic Distortion (0.25 watt to rated continuous average output)**

- 0.02%, with 2-ohm load
- 0.01%, with 4- to 16-ohm load

• **Intermodulation Distortion**

- 0.003%
- **Frequency Response**
 20 to 20,000 Hz, ± 0 dB
 (for rated output, level control at maximum)
 0.5 to 150,000 Hz, +0 dB, -3.0 dB
 (for 1 watt output, level control at maximum)
 0.5 to 80,000 Hz, +0 dB, -3.0 dB
 (for 1 watt output, level control at -6 dB))

- **Gain**
28.0 dB
- **Output Load Impedance**
2 to 16 ohms

- **Damping Factor**
250 (with 8-ohm load, 50 Hz)
- **Input Sensitivity (with 8-ohm load)**
1.13 V (for rated continuous average output)
0.12 V (for 1 watt output)

- **Input Impedance**
Unbalanced: 20 k ohms
Balanced: 40 k ohms
- **Signal-to-Noise Ratio (A-weighted)**
120 dB (input short circuit, rated continuous average output)

- **Power Level Meters**
Logarithmic compression, peak reading meters
dB and direct watt-reading (8-ohm load) scale

- **Semiconductor Complement**
16 transistors, 44 FETs, 10 ICs, 44 diodes
- **Power Requirements**
100 V, 117 V, 220 V, 240 V AC, 50/60 Hz
- **Power Consumption**
350 watts at zero signal input
480 watts in accordance with IEC-65

- **Dimensions**
475 mm (18-23/32 inches) width,
240 mm (9-15/32 inches) max. height,
553 mm (21-3/4 inches) max. depth
- **Weight**
57 kg (125.7 lbs.) net
66 kg (145.4 lbs.) in shipping carton

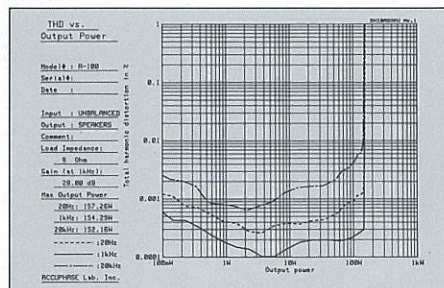

Output power vs. total harmonic distortion (at 8 ohms)

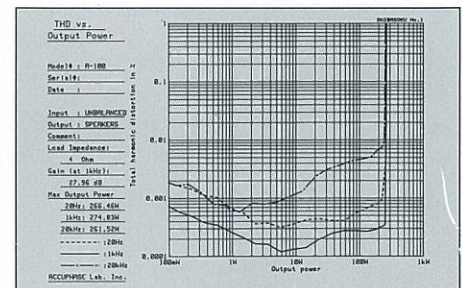

Output power vs. total harmonic distortion (at 4 ohms)

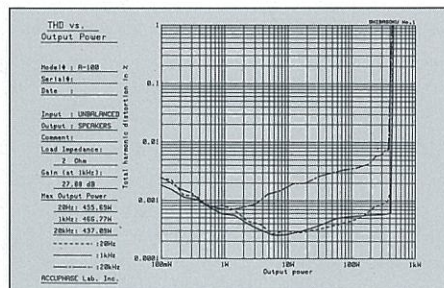

Output power vs. total harmonic distortion (at 2 ohms)

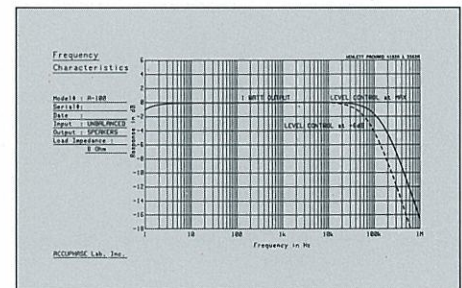

Frequency characteristics



ACCUPHASE LABORATORY INC.

851-0107-00 (GF) PRINTED IN JAPAN